



Designs of distinction[®]
Kitchen, Bath & Home
by BWI

Materials and Components for Kitchen, Bath and Home.
dod.brownwoodinc.com • [@designsofdistinction_kbh](https://www.instagram.com/designsofdistinction_kbh)

TABLE OF CONTENTS

- ii | INTRODUCTION
 - MATERIALS AND FINISHES
 - SECONDARY SERVICES
- 1 | MATERIALS
 - TAMBOUR | **NEW PRODUCTS!**
 - METAL ACCENTS
 - CUT-TO-SIZE MATERIALS | **NEW PRODUCTS!**
- 19 | POSTS & TABLE LEGS
- 34 | END PANELS & STEEL BASES | **NEW PRODUCTS!**
- 41 | BUN FEET
- 51 | BRACKETS & CORBELS | **NEW PRODUCTS!**
- 62 | CREATE-A-COLUMN™ AND HALF ROUND MOULDING | **NEW PRODUCTS!**
- 66 | DECORATIVE MOULDING & PILASTERS
- 68 | SHELVING
- 72 | OUTLETS & VENTS
- 77 | CUSTOM PANEL INSERTS | **NEW PRODUCTS!**
- 81 | GALLERY RAIL
- 84 | DECORATIVE BRASS HARDWARE | **NEW PRODUCTS!**
- 89 | INDEX & WARRANTY



7040 NORTH LAWNDALE AVE. LINCOLNWOOD, IL 60712
(p) 800.328.5858 • (f) 815.425.8777
dod.brownwoodinc.com • @designsofdistinction_kbh • info@brownwoodinc.com

PROUD MEMBERS OF:



©BROWN WOOD INC.
ALL RIGHTS RESERVED 2026
ALL DESIGNS ARE THE EXCLUSIVE PROPERTY OF
BROWN WOOD, INC. AND MAY NOT BE USED OR
REPRODUCED WITHOUT EXPRESS
WRITTEN PERMISSION

ANODIZED ALUMINUM

We use a special aluminum alloy to create our decorative aluminum accents; this special alloy can be chemically brightened. Our aluminum finishes are anodized and feature bright chromes, soft satins and deep matte finishes. Anodizing is considered the best method of finishing in order to achieve a true metallic look. Anodized finishes are extremely durable and will not flake, peel or fade.

If exact color is critical to your project, please request color samples. Sample Kits available on our website.



CR: Chrome



WB: Warm Bronze



SB: Satin Brass



PB: Polished Brass



WR: Flat Black



BA: Brushed Aluminum



SS: Satin Stainless



TM: Titanium

SOLID BRASS

Cast brass, made of a copper/zinc alloy, is known for its material integrity, smooth surface finish, durability, and strength.

Cast brass Feet & Slipper Cups will outlast normal wear and will maintain a bright finish for years to come.

AB: Antique Brass



WR: Flat Black



PB: Polished Brass



CR: Chrome



SB: Satin Brass



WOOD SPECIES

We source only the finest FAS (First and Seconds) hardwoods for our products. The majority of our products are made from laminated blocks with more than one glue line. We strive to provide the best possible color match between staves, but variations may occur. Variations in color and grain pattern are natural characteristics of wood and are not considered defects.



AL: Alder

CH: Cherry

MDF: Medium-Density Fiberboard

HM: Hard Maple

AK: Red Oak

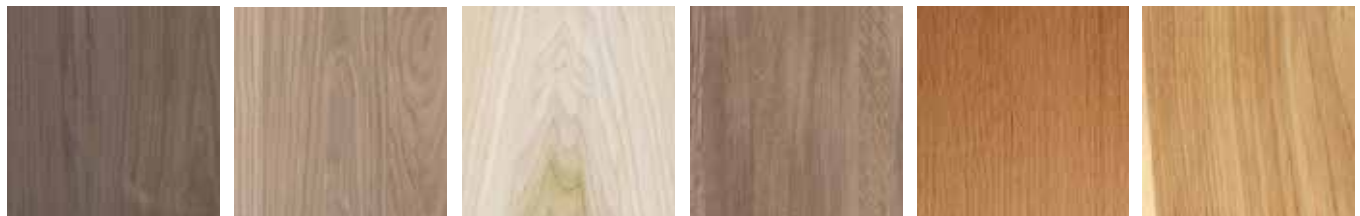

WL: Walnut

WK: White Oak

PT: Paint Grade

QW: Quarter Sawn White Oak

QS: Quarter Sawn Red Oak

HK: Hickory

ELECTROPLATED WIRE GRILLE FINISHES

Our electroplated Decorative Grilles are hand woven & crimped from superior steel wire. The process of electroplating deposits metal finishes onto the steel through electricity creating both bright and antique finishes. Finishes can vary from run to run.

Sample Kits available on our website.

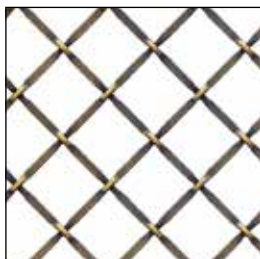

AB: Antique Brass

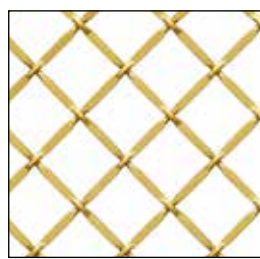

SB: Satin Brass

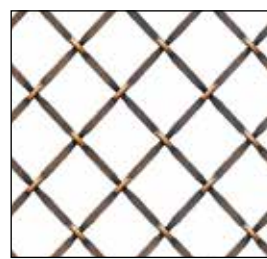

AC: Antique Copper



AP: Antique Pewter



SN: Polished Satin Nickel

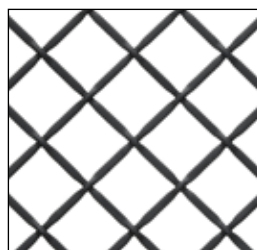

WR: Flat Black

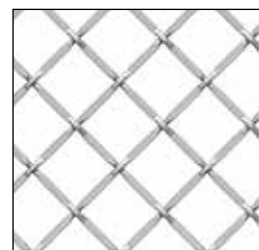

SS: Stainless Steel Look

SPECIAL WOOD CUTS & SECONDARY SERVICES

We are pleased to offer several options to help you in your design process. Secondary services such as splitting in half, quarter notching, electrical outlet notching, and hanger bolt installation are available on the majority of our columns, legs and bun feet. Additional charges apply.

QUARTER CUT



01QUARTERNOTCH

Quarter notching creates a single quartered piece and a single 3/4 piece. Both pieces are included in purchase.

SPLIT



01SPLITCOLUMN

Split column in half. 1/8" of thickness may be lost due to saw kerf. Both halves are included in purchase.

ANGLE CUT



01ANGLECUT

Product is cut at an angle from corner to corner, full length only. Both pieces are included in purchase.

STOP NOTCH



01STOPNOTCH

Stop notch a column. Let us know how far down you would like notched.

SPLIT BUN FOOT



01SPLITFEET

Split bun foot in half. Both pieces are included in purchase.

HANGER BOLT



01HANGERBOLT

5/16-18 hanger bolt installed in one end. Hanger bolt installed to protrude 1/2".

BOX ROUTE



01BXROUTE

Add an electrical box to your column.

ELECTRICAL BORE



01ELECBORE

A 1/2" hole the entire length of the column.

MOULDING & TAMBOUR TRIM

We will cut your 96" moulding to 92" to reduce shipping costs.



Scan for order forms.
<https://bit.ly/SecondaryOpsOrderForms>

*Please note - not all items can be cut in all the formats above, nor can all columns receive an Electrical Box Notch. Please review the product on our website to determine which operations are available or contact customer service at 1-800-328-5858 or orders@brownwoodinc.com for more information.

dod.brownwoodinc.com

All custom cut products are non-returnable.

Our New Website Has Arrived

A More Intuitive Platform to Discover Designs of Distinction

We've reimagined our digital experience to better support how designers, builders, and makers access product information and specification resources for decorative materials and components throughout a project's life cycle. Our new website reflects our refreshed brand and a more intuitive way to work with Designs of Distinction®.

Built for Product Selection and Specification

Designed to support product specification and project execution, the site provides access to technical details, finish options, installation instructions, specification sheets, brochures, and design software catalogs. Product categories on the website now mirror the 2026 Product Catalog—eliminating guesswork and making it easier to find, compare, and specify the right components.

Highlights:

- In-depth product pages with specifications, dimensions, and finish options
- Downloadable specification sheets, installation instructions, and technical resources
- Access to brochures, flyers, and sales tools for project and client presentations
- Design software catalogs compatible with industry-standard platforms
- Organized tools to support repeat ordering and ongoing project management
- Optimized for desktop and mobile access



Visit Us Online: dod.brownwoodinc.com

<https://bit.ly/DesignsOfDistinction>

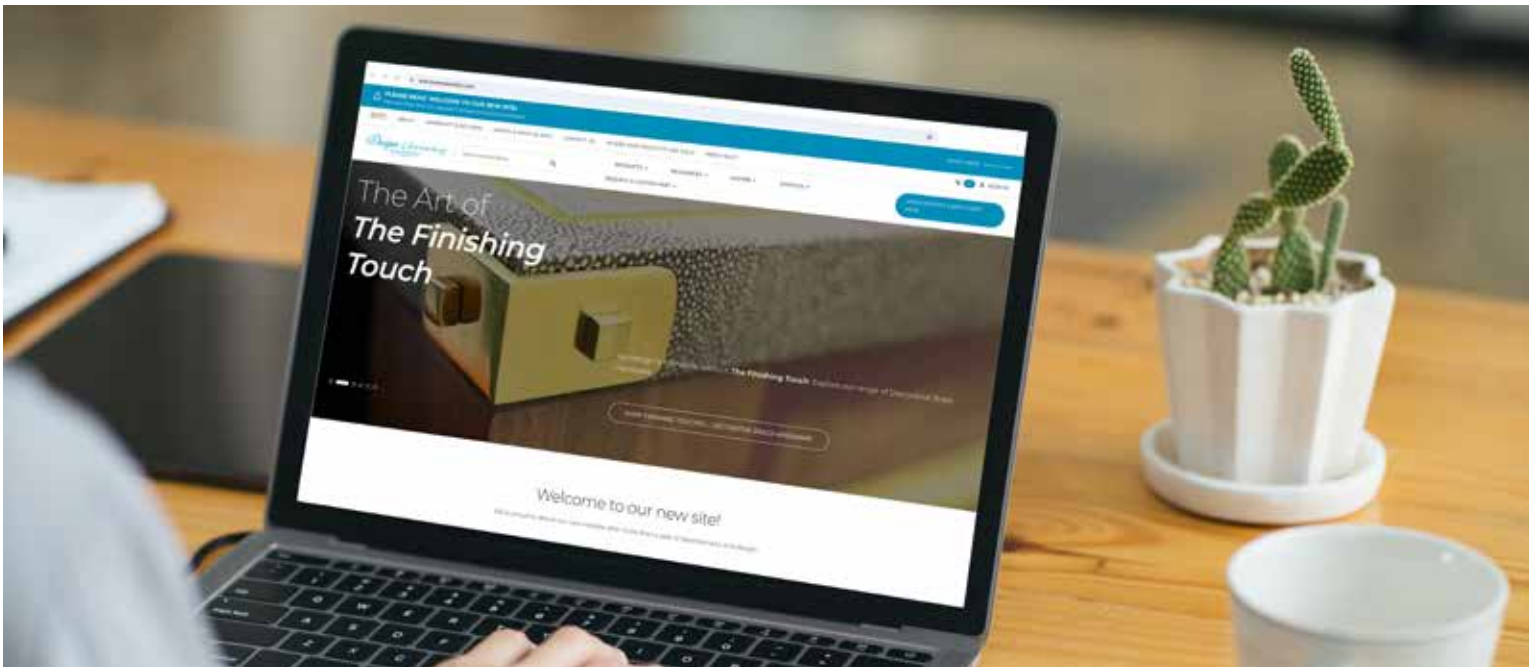

Explore Designs of Distinction®'s Catalog on 3D Warehouse, Chief Architect, and more.



Subscriptions may be required.

MATERIALS: FLEXIBLE TAMBOUR & RIGID BEADED PANELS

Image: Flexible Beaded Tambour



FLEXIBLE TAMBOUR PANELS

Made in the USA. Our thin material backer allows Flexible Panels to be used as a wrap as well as flat applications. Flexible beaded panels consist of individual staves, glued to a flexible canvas or paper backer. Suitable for residential and commercial applications. Unfinished American Hardwoods can be easily stained or painted in colors and finishes of your choice.

For **onlay** applications - such as walls, hoods, or cabinet wraps. 48" and 96" lengths in stock. Custom sizes available.

Stock finishes in: Red Oak (AK), Hard Maple (HM), Paint Grade Poplar (PT), Walnut (WL) & White Oak (WK).
To order, refer to the style numbers listed below.



STYLE 100	STYLE 101	STYLE 102
<p>011248100-1 12"W x 48"L x .25"T 011296100-1 12"W x 96"L x .25"T 012448100-1 24"W x 48"L x .25"T</p>	<p>011248101-1 12"W x 48"L x .313"T 011296101-1 12"W x 96"L x .313"T</p>	<p>011248102-1 12"W x 48"L x .375"T 011296102-1 12"W x 96"L x .375"T 012448102-1 24"W x 48"L x .375"T</p>
STYLE 103	STYLE 104	STYLE 105
<p>011248103-1 12"W x 48"L x .313"T 011296103-1 12"W x 96"L x .313"T</p>	<p>011248104-1 12"W x 48"L x .5"T 011296104-1 12"W x 96"L x .5"T</p>	<p>011248105-1 12"W x 48"L x .375"T 011296105-1 12"W x 96"L x .375"T</p>
STYLE 106	STYLE 107	STYLE 110
<p>011248106-1 12"W x 48"L x .75"T 011296106-1 12"W x 96"L x .75"T</p>	<p>011248107-1 12"W x 48"L x .375"T 011296107-1 12"W x 96"L x .375"T 012448107-1 24"W x 48"L x .375"T 012434107-1 24"W x 34"L x .375"T</p>	<p>011248110-1 12"W x 48"L x .25"T 011296110-1 12"W x 96"L x .25"T 012448110-1 24"W x 48"L x .25"T</p>



<https://bit.ly/FlexibleTambour>

MATERIALS

Check our price list or website for product species availability.

AK: Red Oak	HM: Hard Maple	MDF: Medium Density Fiberboard	PT: Paint Grade	WL: Walnut	WK: White Oak
-----------------------	--------------------------	---	---------------------------	----------------------	-------------------------

FLEXIBLE TAMBOUR PANELS

Made in the USA. Our thin material backer allows Flexible Panels to be used as a wrap as well as flat applications. Flexible beaded panels consist of individual staves, glued to a flexible canvas or paper backer. Suitable for residential and commercial applications. Unfinished American Hardwoods can be easily stained or painted in colors and finishes of your choice.

For **onlay** applications - such as walls, hoods, or cabinet wraps. 48" and 96" lengths in stock. Custom sizes available.

Stock finishes in: Red Oak (AK), Hard Maple (HM), Paint Grade Poplar (PT), Walnut (WL) & White Oak (WK).
To order, refer to the style numbers listed below.

SQUARE

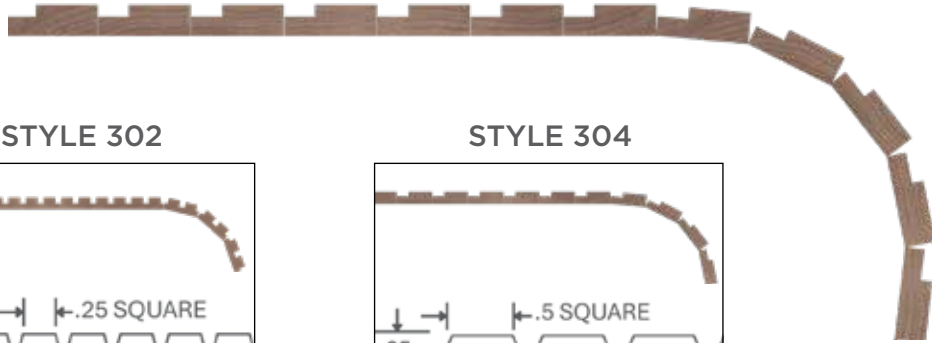

STYLE 302

.25 SQUARE

.25

.75

011248302-1
12"W x 48"L x .25"T
011296302-1
12"W x 96"L x .25"T
012448302-1
24"W x 48"L x .25"T

STYLE 304

.5 SQUARE

.25

.75

011248304-1
12"W x 48"L x .25"T
011296304-1
12"W x 96"L x .25"T
012448304-1
24"W x 48"L x .25"T

COVE

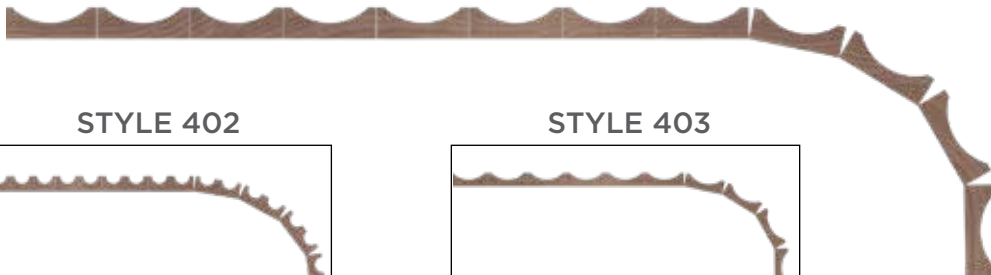

STYLE 402

.25 COVE

.25

.75

011248402-1
12"W x 48"L x .25"T
011296402-1
12"W x 96"L x .25"T
012448402-1
24"W x 48"L x .25"T

STYLE 403

.625 COVE

.25

.75

011248403-1
12"W x 48"L x .25"T
011296403-1
12"W x 96"L x .25"T
012448403-1
24"W x 48"L x .25"T

FLEXIBLE TAMBOUR PANELS

Made in the USA. Our thin material backer allows Flexible Panels to be used as a wrap as well as flat applications. Flexible beaded panels consist of individual staves, glued to a flexible canvas or paper backer. Suitable for residential and commercial applications. Unfinished American Hardwoods can be easily stained or painted in colors and finishes of your choice.

For **onlay** applications - such as walls, hoods, or cabinet wraps. 48" and 96" lengths in stock. Custom sizes available.

Stock finishes in: Red Oak (AK), Hard Maple (HM), Paint Grade Poplar (PT), Walnut (WL) & White Oak (WK).
To order, refer to the style numbers listed below.

BEVEL

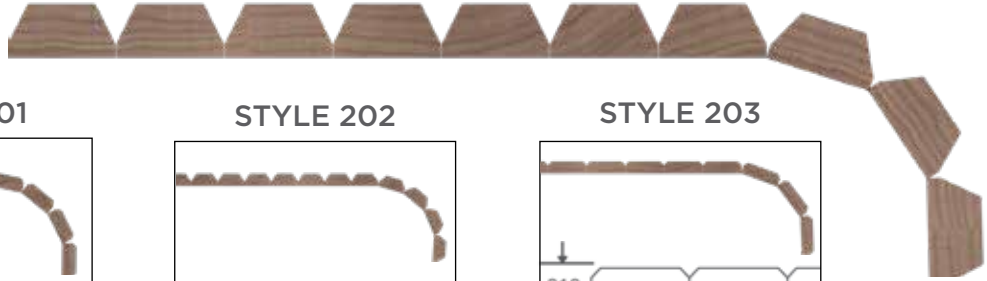

STYLE 201

011248201-1
12"W X 48"L X .313"T
011296201-1
12"W X 96"L X .313"T

STYLE 202

011248202-1
12"W X 48"L X .344"T
011296202-1
12"W X 96"L X .344"T

STYLE 203

011248203-1
12"W X 48"L X .313"T
011296203-1
12"W X 96"L X .313"T
012448203-1
24"W X 48"L X .313"T
012434203-1
24"W X 34"L X .313"T

STYLE 204

011248204-1
12"W X 48"L X .5"T
011296204-1
12"W X 96"L X .5"T

STYLE 206

011248206-1
12"W X 48"L X .344"T
011296206-1
12"W X 96"L X .344"T

STYLE 207

011248207-1
12"W X 48"L X .75"T
011296207-1
12"W X 96"L X .75"T



Image: Flexible Tambour Panels

RIGID PANELS

Multiple styles work with both furniture and architectural applications. Unfinished, ready to stain or paint. **Red Oak (AK), Hard Maple (HM), Paint Grade Brown Maple (PT), Walnut (WL) & White Oak (WK)**, in 46" lengths available. **Some Styles Available In: Cherry, Alder, Hickory, HDF, Quarter Sawn White Oak & Quarter Sawn Red Oak.**

BEAD



<p>STYLE 100</p> <p>012446100-1 24"W x 46"L x .25"T</p>	<p>STYLE 107</p> <p>012446107-1 24"W x 46"L x .375"T</p>	<p>STYLE 102</p> <p>012446102-1 24"W x 46"L x .375"T</p>
<p>STYLE 110</p> <p>012446110-1 24"W x 46"L x .25"T</p>	<p>STYLE 127</p> <p>012446127-1 24"W x 46"L x .25"T</p>	

SQUARE



<p>STYLE 302</p> <p>012446302-1 24"W x 46"L x .25"T</p>	<p>STYLE 304</p> <p>012446304-1 24"W x 46"L x .25"T</p>
---	---

COVE



<p>STYLE 402</p> <p>012446402-1 24"W x 46"L x .25"T</p>	<p>STYLE 403</p> <p>012446403-1 24"W x 46"L x .25"T</p>
---	---



<https://bit.ly/RigidPanels>

MATERIALS

NEW! 3/4" T x 96" L x 48" W CROSS-GRAIN VENEER BACKED BEADED PANEL

Full Size Rigid Panels combine tambour texture with engineered stability in a 3/4" panel designed for cabinetry, millwork, and architectural applications.

Balanced & Stable Construction - Cross-grain hardwood veneer backer and 1/2" plywood core minimize warping, cupping, and seasonal movement while maintaining strength without excess weight.

Beaded Face with Visual Texture - Tambour detailing adds depth and dimension, complementing design styles from traditional to contemporary.

Standard 3/4" Thickness - Integrates seamlessly into standard cabinetry and millwork with no special hardware or joinery adjustments.

Finished Back for Exposed Applications - Veneer backer provides a clean, finished appearance for islands, open shelving, and freestanding installations.

Efficient, Cost-Effective Design - Combines the beauty of solid wood with an engineered core for responsible material use and premium value.

NEW! 8' x 4' FULL SIZE RIGID PANELS



A. Beaded Rigid Panel

B. 1/2" Plywood Core

C. Cross-Grain Veneer Backer

019648127-1
96"W X 48"H X .75"T

014848127-1
48"W X 48"H X .75"T

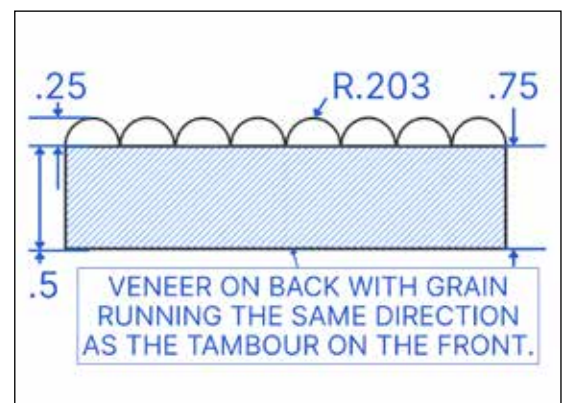

MATERIALS: METAL ACCENT TRIM

Image: .25 x .25 Decorative Bars

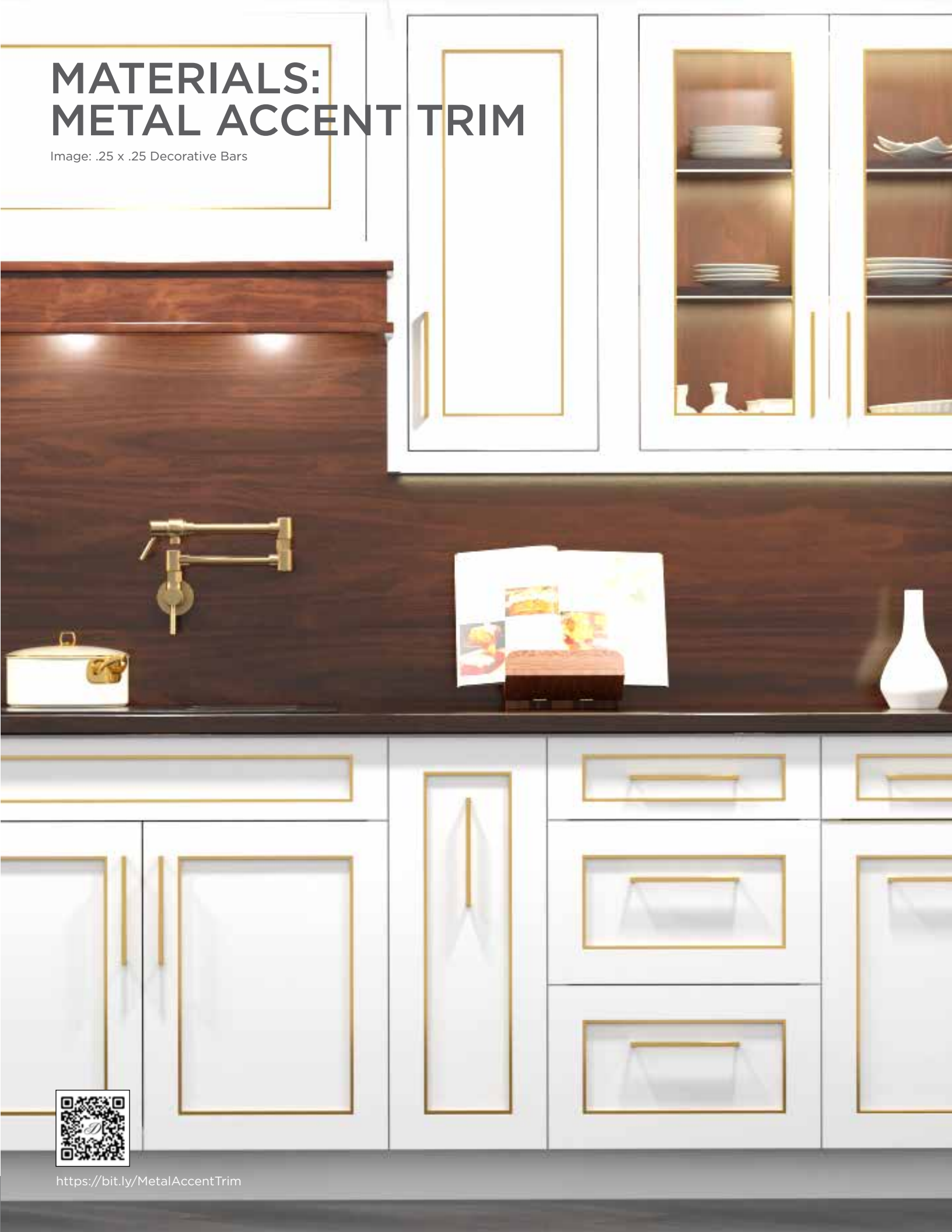

<https://bit.ly/MetalAccentTrim>

METAL ACCENT TRIM

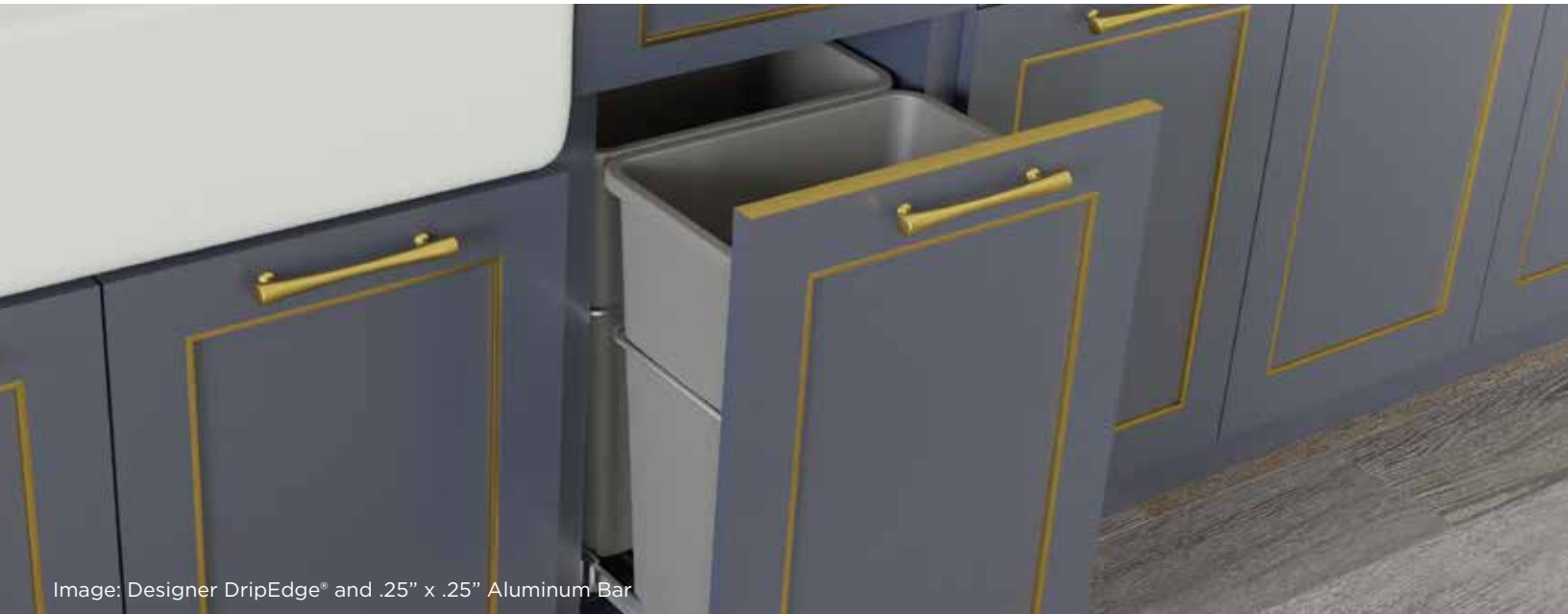
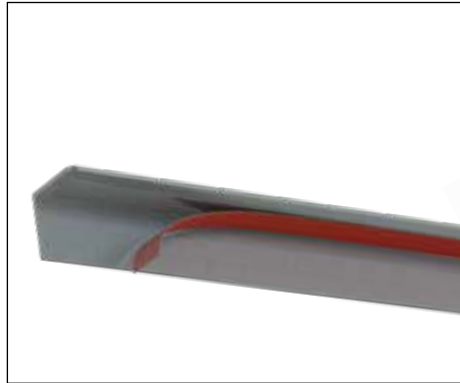
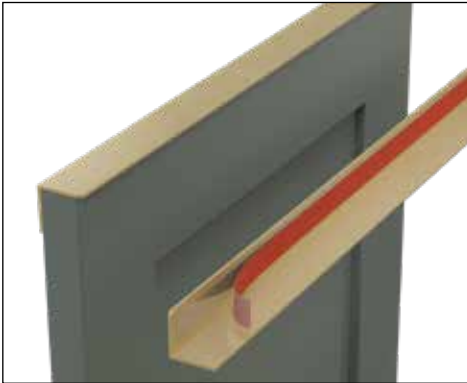

Image: Designer DripEdge® and .25" x .25" Aluminum Bar

DESIGNER DRIPEDGE®

Fits standard waste can cabinets from 12" to 24".
Features eased ends and includes pre-applied UHB tape for easy installation.



010451-1-1181 11.8125" Long	010451-1-1875 18.75" Long
01110451-1-12 12.75" Long	010451-1-2050 20.50" Long
01110451-1-14 14.50" Long	010451-1-2081 20.8125" Long
010451-1-1481 14.8125" Long	010451-1-2175 21.75" Long
01110451-1-15 15.75" Long	010451-1-2350 23.50" Long
01110451-1-17 17.50" Long	010451-1-2384 23.844" Long
010451-1-1781 17.8125" Long	Sample Kit 01DripEdgeCLR

ALUMINUM TOUCH-UP PEN



- 01PENWR1**
Flat Black (WR)
- 01PENBR1**
Polished Brass (PB)
& Satin Brass (SB)
- 01PENST1**
Satin Stainless (ST)
- 01PENTM1**
Titanium (TM)
- 01PENWB1**
Warm Bronze (WB)

BA & CR do not have touch-up pens

UHB TAPE



01TP50-108
1/2" x 108"

01TP1875-54
3/16" x 54"

01TP50-8
1/2" x 8'

01TP1875-8
3/16" x 8'

ALUMINUM BARS

Available in 72" lengths, the straps can be cut on-site to fit your specifications using a lubricated, non-ferrous, high tooth count carbide blade (96 is recommended) designed for cutting metal. We stock strong, double-sided, clear industrial tape that's temperature resistant to adhere metal trim to mouldings and cabinet panels. Metallic Trim stocked in **Brushed Aluminum (BA)**, **Chrome (CR)**, **Flat Black (WR)**, **Polished Brass (PB)**, **Satin Brass (SB)**, **Satin Stainless (ST)**, **Titanium (TM)** & **Warm Bronze (WB)**.



ALUMINUM ANGLED BARS

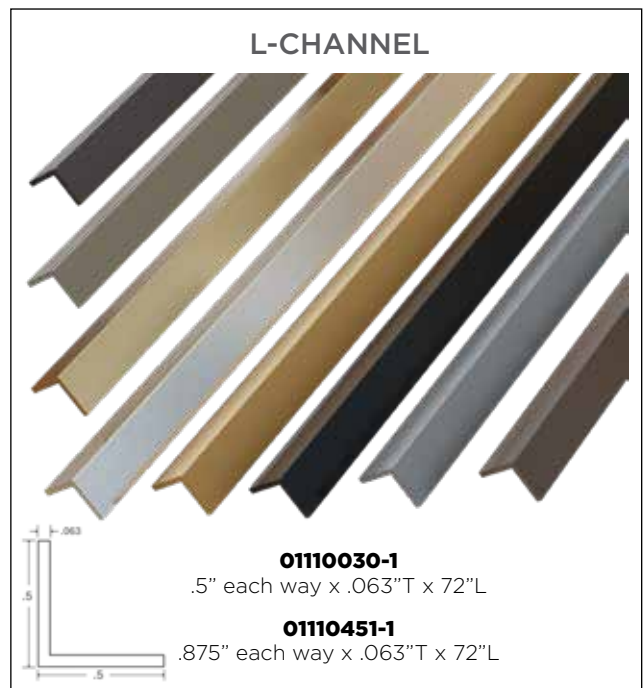

Check our price list or website for finishes available per profile.

MATERIALS

BA:
Brushed
Aluminum

CR:
Chrome

PB:
Polished Brass

SB:
Satin Brass

ST:
Satin Stainless

TM:
Titanium

WB:
Warm Bronze

WR:
Flat Black

ALUMINUM STRAPPING

Metallic Trim Accents stocked in 72" lengths: **Brushed Aluminum (BA)**, **Chrome (CR)**, **Flat Black (WR)**, **Polished Brass (PB)**, **Satin Brass (SB)**, **Satin Stainless (ST)**, **Titanium (TM)** & **Warm Bronze (WB)**.

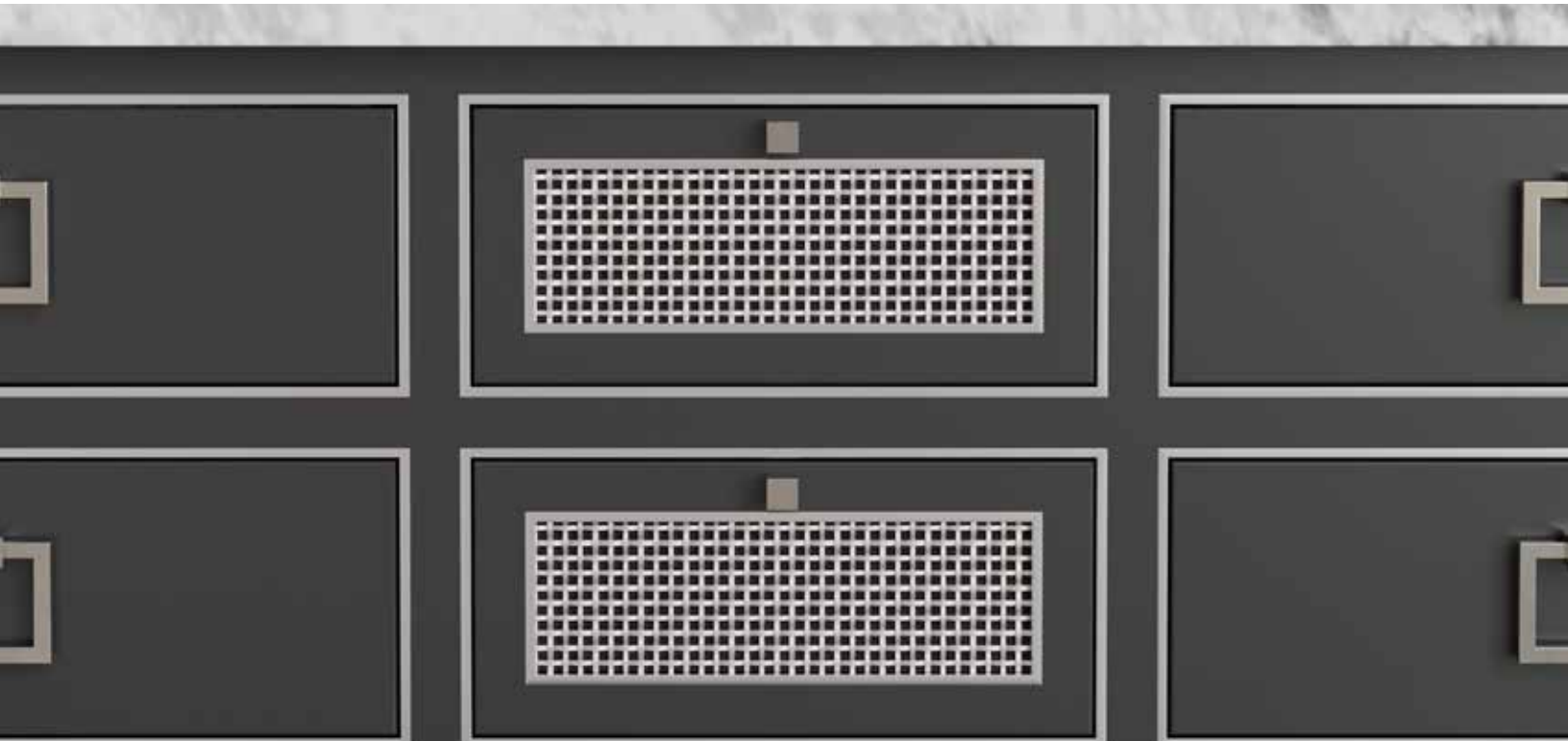
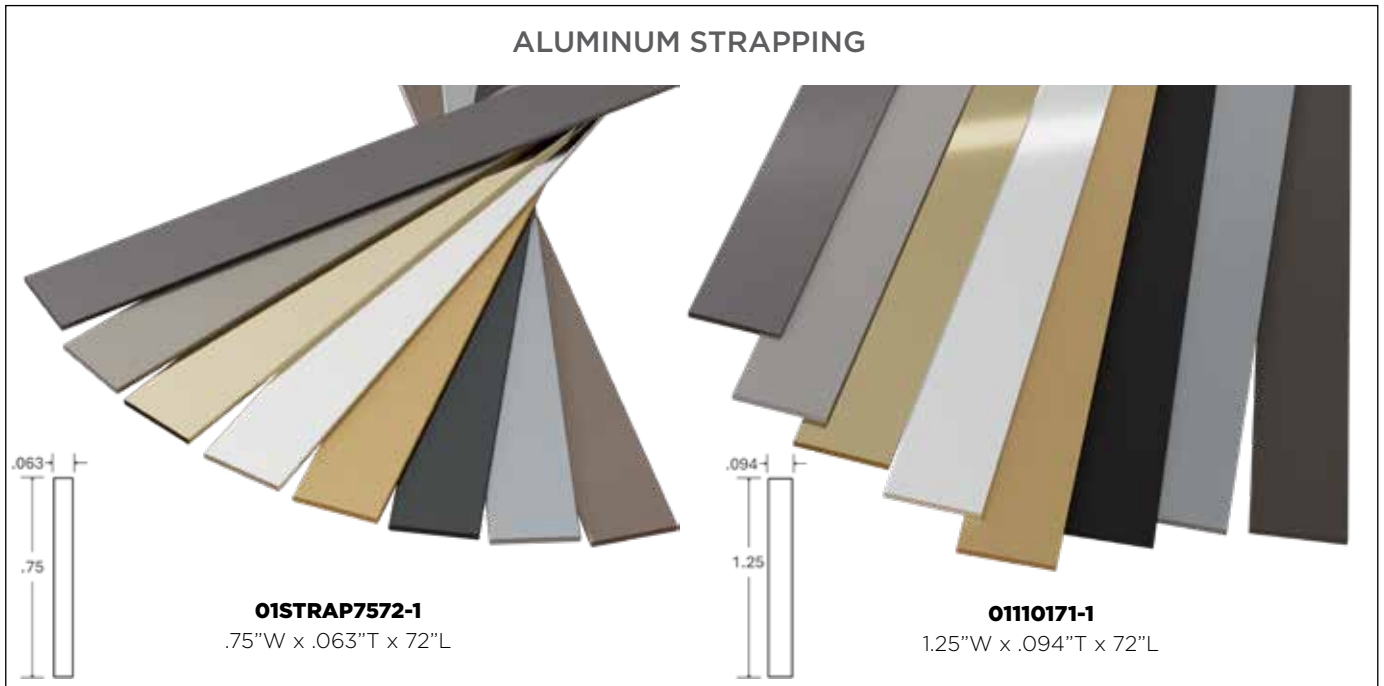

Image: Decorative Grille and .25" x .25" Aluminum Bar

MATERIALS

Check our price list or website for finishes available for product.

BRASS TRIM COMPONENTS



Image: 1/2" Brass Corner Strap

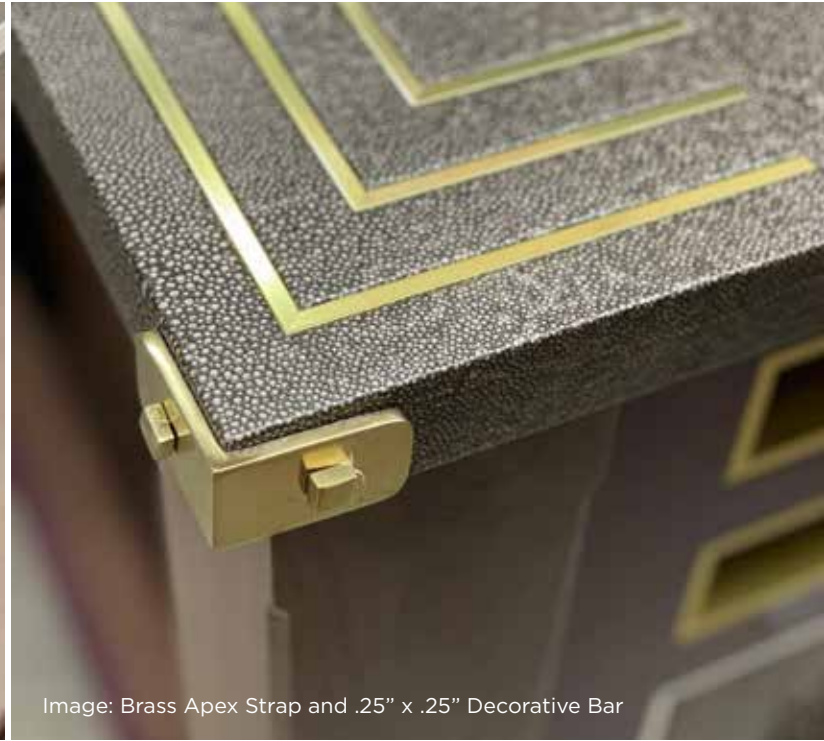

Image: Brass Apex Strap and .25" x .25" Decorative Bar

1/2" BRASS CORNER STRAP



01HC1005-1
1.5" Each Way x .08"T
Available in PB & PN

1/2" BRASS STRAP CONNECTOR



01HC1010-1
.512"W x .08"T x 2"L
Available in PB & PN

BRASS APEX STRAP



01HC1008-1
2" Each Way x .197"T x 1.181"H
Available in AB, CR, PB, PN, SB, WR

1/4" BRASS BAR



01990810-1
.25" SQ. x 72" L
Available in PB & SB

3/8" BRASS STRAP



01HC1007-1
.375"W x .063"T x 48"L
Available in PB & PN

Check our price list or website for product finishes available per style.

MATERIALS

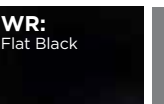
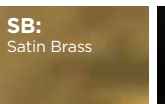
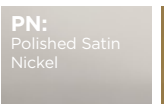
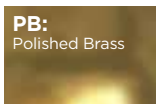
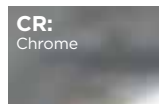
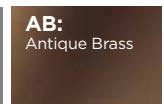

AB:
Antique Brass

CR:
Chrome

PB:
Polished Brass

PN:
Polished Satin
Nickel

SB:
Satin Brass

WR:
Flat Black

MATERIALS: CUT-TO-SIZE



CUT-TO-SIZE MATERIALS

Sold by the square or linear foot (LF).



Image: Decorative Grille layered with Mesh

Decorative Grilles available in **Antique Brass (AB)**, **Antique Copper (AC)**, **Antique Pewter (AP)**, **Satin Brass (SB)**, **Polished Satin Nickel (SN)**, **Stainless Look (SS)** & **Flat Black (WR)**. Finishes are created through an electroplating process. To order Cut-to-Size panels that are ready to install upon delivery, contact us by sending an order form available on our website with your panel specifications and a quote will be provided based on square footage. Sample Kits available for purchase on our website.

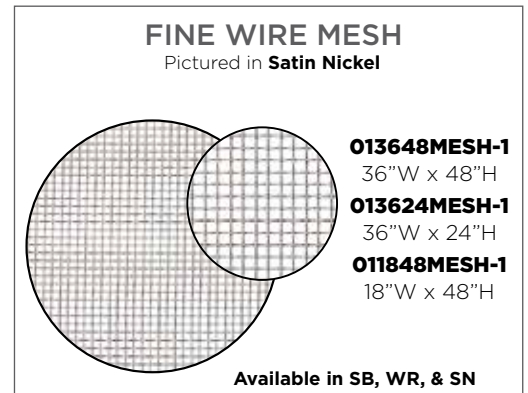
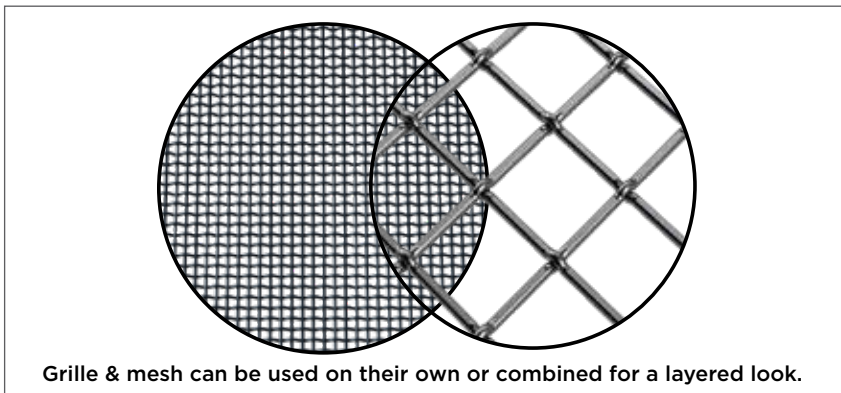

Check our price list or website for finishes available per style.

MATERIALS

AB:
Antique Brass

AC:
Antique Copper

AP:
Antique Pewter

SB:
Satin Brass

SN:
Satin Nickel

SS:
Stainless Look

WR:
Flat Black

DIAMOND DECORATIVE GRILLE

Decorative Grilles are available in **Antique Brass (AB), Antique Copper (AC), Antique Pewter (AP), Natural Aluminum (NA), Satin Brass (SB), Polished Satin Nickel (SN), Stainless Look (SS), Warm Bronze (WB) & Flat Black (WR)** unless otherwise noted. Available Cut-to-Size or as full and half sheets. Custom styles and finishes available upon request.

NEW!

NEW!

#M22
.375" Flat Crimped Double Diamond
 Pictured in **Antique Brass, 2-sided**
 Front



Back

013648M22-1 36"W x 48"H
013624M22-1 36"W x 24"H
012472M22-1 24"W x 72"H
011848M22-1 18"W x 48"H

Available in AB, SB, SN, & WR

#226
.05" Flat Rigid Aluminum Grille
 Pictured in **Natural Aluminum**

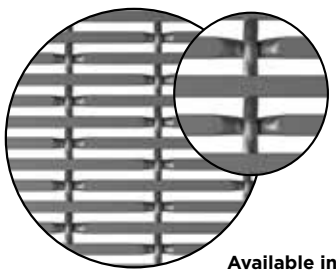

014848226-1 48"W x 48"H
012448226-1 24"W x 48"H

Available in NA, WB, & WR

#332P
.75" Multi-Crimp Single Diamond
 Pictured in **Antique Pewter**



013648332P-1 36"W x 48"H
013624332P-1 36"W x 24"H
012472332P-1 24"W x 72"H
011848332P-1 18"W x 48"H

#CG10
.5" Straight Flat Diamond
 Pictured in **Antique Brass**



013648CG10-1 36"W x 48"H
013624CG10-1 36"W x 24"H
012472CG10-1 24"W x 72"H
011848CG10-1 18"W x 48"H

#286S
.375" Flat Single Diamond
 Pictured in **Polished Satin Nickel**

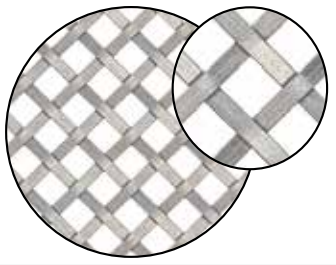

013648286S-1 36"W x 48"H
013624286S-1 36"W x 24"H
012472286S-1 24"W x 72"H
011848286S-1 18"W x 48"H

#DK08
Double-Sided .375" Flat/Fluted
 Pictured in **Satin Brass, 2-Sided**

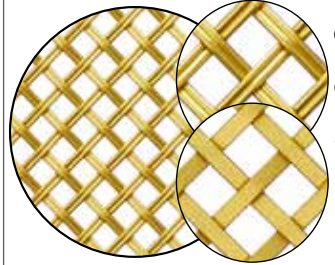

013648DK08-1 36"W x 48"H
013624DK08-1 36"W x 24"H
012472DK08-1 24"W x 72"H
011848DK08-1 18"W x 48"H

#11614P
1" Flat Double Diamond
 Pictured in **Flat Black**

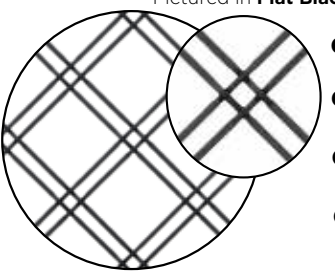

01364811614P-1 36"W x 48"H
01362411614P-1 36"W x 24"H
01247211614P-1 24"W x 72"H
01184811614P-1 18"W x 48"H

#1214F
.5" Round Single Diamond
 Pictured in **Antique Copper**



0136481214F-1 36"W x 48"H
0136241214F-1 36"W x 24"H
0124721214F-1 24"W x 72"H
0118481214F-1 18"W x 48"H

#1220T
5" Chicken Wire
 Pictured in **Antique Pewter**

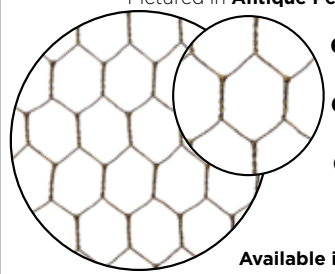

0136481220T-1 36"W x 48"H
0136241220T-1 36"W x 24"H
0118481220T-1 18"W x 48"H

Available in AB, AP, & WR.

#R332P
.75" Multi-Crimp Single Diamond with .625" Rosettes



013648R332PAB1 36"W x 48"H
013624R332PAB1 36"W x 24"H
011848R332PAB1 18"W x 48"H

Only Available in Antique Brass

#R614P
1" Flat Double Diamond with .625" Rosettes

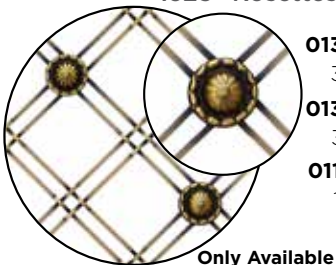

013648R614PAB1 36"W x 48"H
013624R614PAB1 36"W x 24"H
011848R614PAB1 18"W x 48"H

Only Available in Antique Brass

#315C
.75" Pressed Single Diamond
 Pictured in **Polished Satin Nickel**



013648315C-1 36"W x 48"H
013624315C-1 36"W x 24"H
012472315C-1 24"W x 72"H
011848315C-1 18"W x 48"H

MATERIALS

SQUARE DECORATIVE GRILLE

Most Decorative Grilles are available in **Antique Brass (AB)**, **Antique Copper (AC)**, **Antique Pewter (AP)**, **Satin Brass (SB)**, **Polished Satin Nickel (SN)**, **Stainless Look (SS)** & **Flat Black (WR)** unless otherwise noted. Available Cut-to-Size or as whole and half sheets. Custom styles and finishes available upon request.

#SQ214F
.5" Round Single Diamond
 Pictured in **Stainless Look**

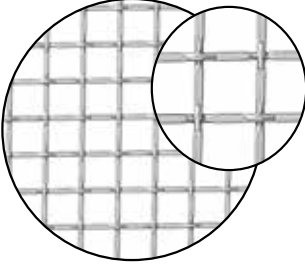

01SQ3648214F-1
 36" W x 48" H
01SQ3624214F-1
 24" W x 36" H
01SQ2472214F-1
 24" W x 72" H
01SQ1848214F-1
 18" W x 48" H

#SQ286S
.375" Flat Single Diamond
 Pictured in **Satin Brass**



01SQ3648286S-1
 36" W x 48" H
01SQ3624286S-1
 24" W x 36" H
01SQ2472286S-1
 24" W x 72" H
01SQ1848286S-1
 18" W x 48" H

#SQDK08
Double-Sided .375"
 Pictured in **Antique Brass**



01SQ3648DK08-1
 36" W x 48" H
01SQ3624DK08-1
 24" W x 36" H
01SQ2472DK08-1
 24" W x 72" H
01SQ1848DK08-1
 18" W x 48" H

#SQ332P
.75" Multi-Crimp Single Square
 Pictured in **Antique Brass**

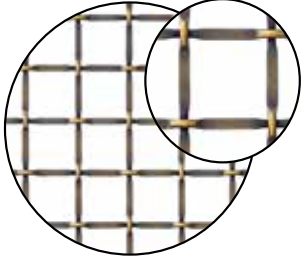

01SQ3648332P-1
 36" W x 48" H
01SQ3624332P-1
 24" W x 36" H
01SQ2472332P-1
 24" W x 72" H
01SQ1848332P-1
 18" W x 48" H

#RE25
.1875" Flat Square
 Pictured in **Satin Brass**



013648RE25-1
 36" W x 48" H
013624RE25-1
 24" H x 36" W
012472RE25-1
 24" W x 72" H
011848RE25-1
 18" W x 48" H

GRILLE RETAINER



01DGRETAINDER-1
 Cut-to-Size to fit your decorative grille.
 Transparent vinyl. Sold by the linear foot.



Cut-to-Size Sample Kits available.

Available Cut-to-Size and as full and half sheets.

Custom styles and finishes available upon request.

Check our price list or website for finishes available per style.



<https://bit.ly/CTS-SampleKits>

MATERIALS

AB:
Antique Brass

AC:
Antique Copper

AP:
Antique Pewter

SB:
Satin Brass

SN:
Satin Nickel

SS:
Stainless Look

WR:
Flat Black

ITALIAN MESH

Made in Italy.

Sold by the linear foot (LF), minimum order of 59" wide x 1 LF.

NEW!
INTERLACE STRIPE MESH
Available in **CP, PB, SS**

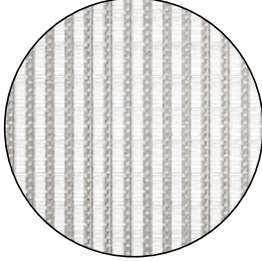

Style #103

NEW!
SUPERFINE WIRE MESH
Available in **CP, SB, SS**

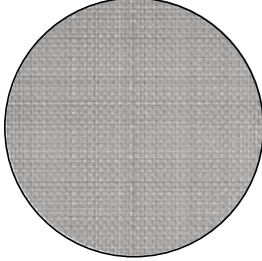

Style #110

CHEVRON MESH
Available in **CP, SB, SS**

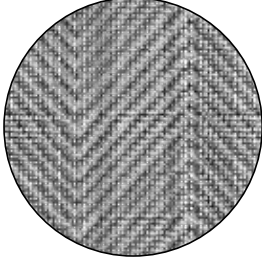

Style #107

JUTE MESH
Available in **SS**

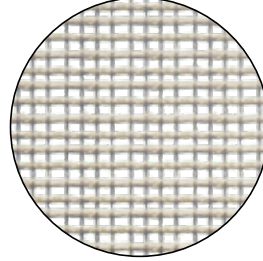

Style #112

RESIN PANELS

Sold by the linear foot (LF), minimum order of 48" wide x 1 LF.

WHITE LINEN

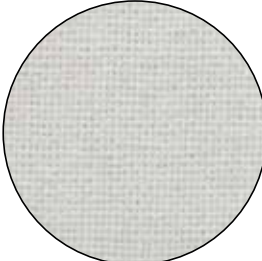

Style #1803

BOTANICAL



Style #1804

NATURAL LEAF



Style #1802

RATTAN WEBBING

Sold by the linear foot (LF), minimum order of 36" wide x 1 LF.

NEW! SYNTHETIC RATTAN WEBBING

Our new synthetic rattan webbing combines timeless woven design with modern durability. Manufactured from high-quality polyethylene (PE) granules, this material offers exceptional strength while remaining practically maintenance-free. Unlike natural rattan, it resists fading, warping, or weakening from temperature and humidity changes, ensuring long-lasting structure and performance. 36"W rolls. Available in Natural (NT) or Black (WR).

HEX RATTAN

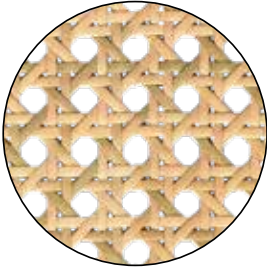

Style #3202NT

HEX RATTAN

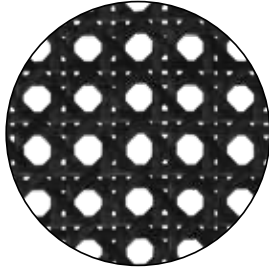

Style #3202WR

RADIO WEAVE

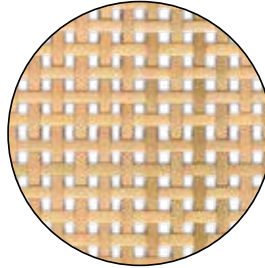

Style #3201NT

RADIO WEAVE

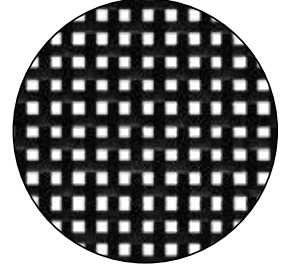

Style #3201WR

NATURAL RATTAN WEBBING

Handwoven from rattan cane, this material offers a lightweight yet durable construction. Over time, it develops a rich patina, adding to its authenticity and charm. Because it is a natural fiber, rattan is responsive to its environment. Gradually, it may stretch, lose some of its original tension, or change shape, particularly in areas exposed to heat, humidity, or fluctuating moisture levels. 36"W rolls.

HEX RATTAN

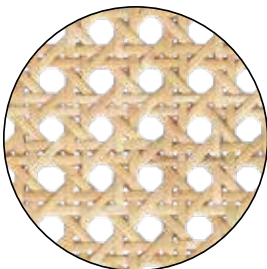

Style #1202NT

HERRINGBONE

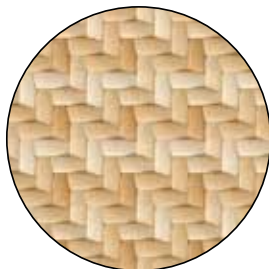

Style #1203NT

BASKETWEAVE

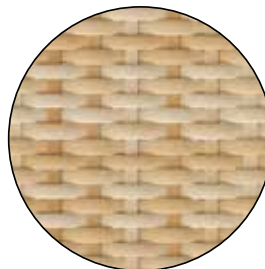

Style #1204NT

RADIO WEAVE

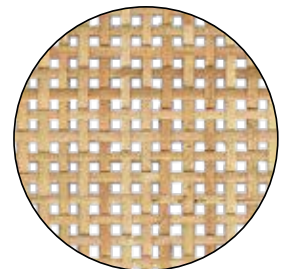

Style #1201NT



Image: Hex Rattan

ECO-FRIENDLY LEATHER

NEW! PEEL & STICK LEATHER SHEETS

Sold by the linear foot (LF), minimum order of 48" wide x 1 LF.

GRAINED FLAT BLACK



Style #3216WR

CROCODILE FLAT BLACK



Style #5618WR

PEBBLED WALNUT

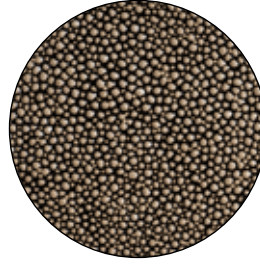

Style #2652WL

PEBBLED FLAT BLACK

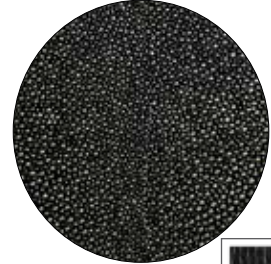

Style #2652WR



Adhesive Back

DOUBLE-SIDED PEBBLED LEATHER PANEL

Sold by the linear foot (LF), minimum order of 48" wide x 1 LF.

BRIGHT WHITE

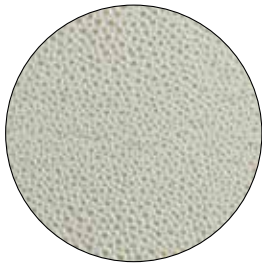

Style #1652BW

WALNUT

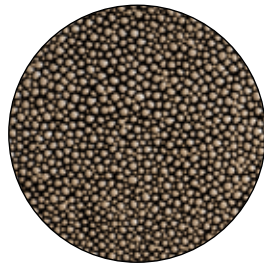

Style #1652WL

ESPRESSO

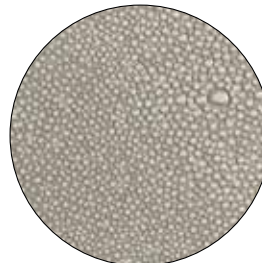

Style #1652ES

FLAT BLACK



Style #1652WR

DOUBLE-SIDED GRAINED LEATHER PANEL

Sold by the linear foot (LF), minimum order of 48" wide x 1 LF.

BRIGHT WHITE



Style #2216BW

WALNUT



Style #2216WL

ESPRESSO



Style #2216ES

FLAT BLACK



Style #2216WR



POSTS & TABLE LEGS

Image: Square Island Posts with Chamfered Detail



<https://bit.ly/Posts-TableLegs>

18" - 29" TABLE LEGS



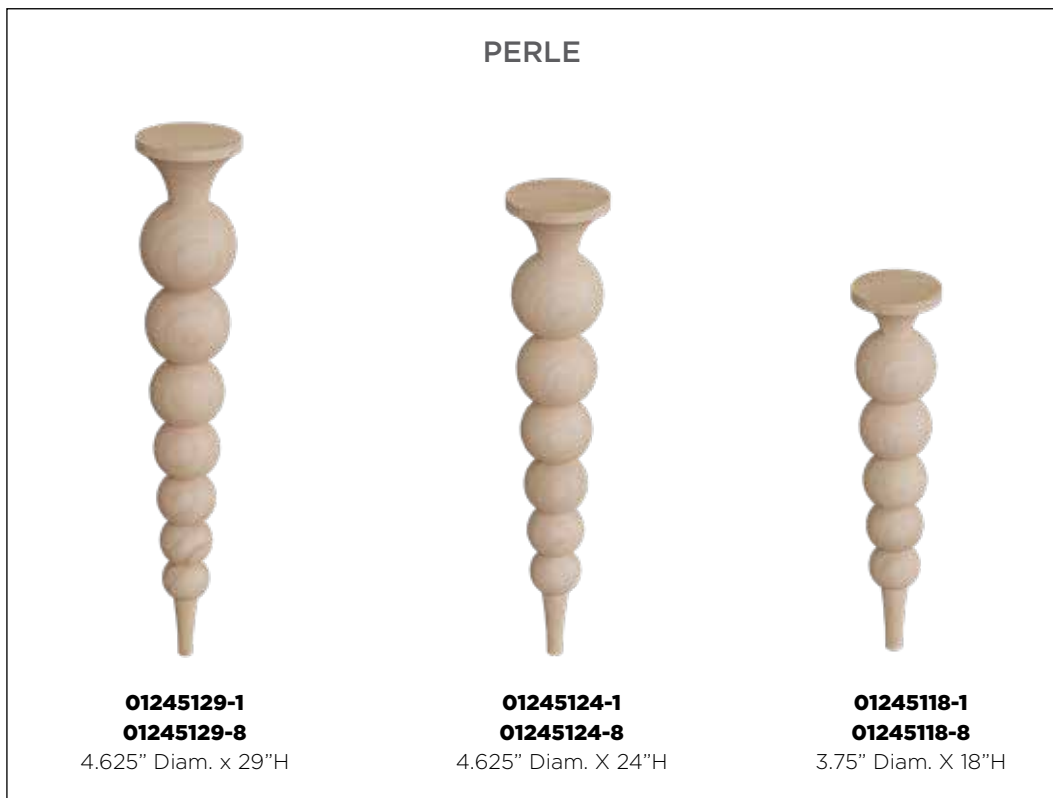
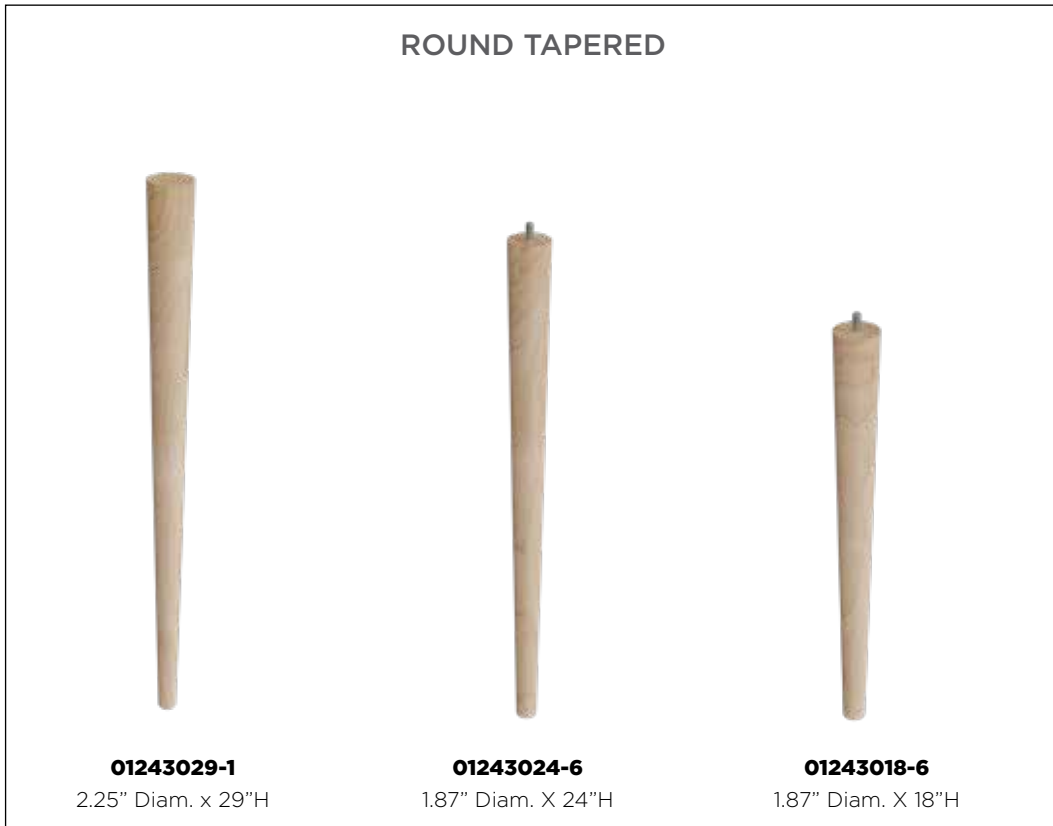

(-6): includes a pre-installed 5/16-18 hanger bolt protruding .75" (-8): includes clear-coat semi-gloss finish



29" SQUARE TABLE LEGS

(-3): indicates notching in the leg

<p>2" SQUARE</p>  <p>01612010-1 2" SQ. x 29"H</p>	<p>2" SQUARE NOTCHED</p>  <p>01612010-3 2" SQ. x 29"H</p>	<p>2" SQUARE COLUMN W/ METAL SLEEVE</p>  <p>01722910-1 2" SQ. x 29"H with 2" SQ. sleeve</p> <p>01724529-1 2" SQ. x 29"H with 2" SQ. x 4.5"H sleeve</p>	
--	--	---	--

<p>2" SQUARE W/ TAPERED FOOT</p>  <p>01621025-1 2" SQ. x 29"H</p>	<p>2" SQUARE W/ TAPERED FOOT & NOTCH</p>  <p>01621025-3 2" SQ. x 29"H</p>	<p>3" SQUARE</p>  <p>01613010-1 3" SQ. x 29"H</p>	<p>3" SQUARE W/ TAPERED FOOT</p>  <p>01613025-1 3" SQ. x 29"H</p>
--	--	---	--

Check our price list or website for product species available per product.

POSTS & LEGS

AK:
Red Oak

AL:
Alder

CH:
Cherry

HM:
Hard Maple

HK:
Hickory

PT:
Paint Grade



WK:
White Oak

WL:
Walnut

29" TABLE LEGS

<p>3" SQUARE LEG W/ METAL SLEEVE</p>  <p>01723001-1 3" SQ. x 29"H with 3" SQ. sleeve</p>	<p>3" SQUARE LEG W/ METAL SLEEVE</p>  <p>01734529-1 3" SQ. x 29"H with 3" x 4.5" SQ. sleeve</p>	<p>4" SQUARE COLUMN W/ METAL SLEEVE</p>  <p>01724001-1 4" SQ. x 29"H with 4" SQ. sleeve</p>	<p>4" SQUARE</p>  <p>01614010-1 4" SQ. x 29"H</p>	<p>4" SQUARE W/ TAPERED FOOT</p>  <p>01614025-1 4" SQ. x 29"H</p>
---	--	--	--	--



29" TURNED TABLE LEGS

<p>ESTATE SQUARE</p>  <p>01040127-1 2.75" SQ. x 29.25"H 01040160-1 3.75" SQ. x 29.25"H 01220160-1 5" SQ. x 29.25"H</p>			<p>KENSINGTON</p>  <p>01110110-1 3" SQ. x 29"H</p>	<p>COUNTRY FRENCH SQUARE</p>  <p>01060160-1 3.75" SQ. x 29.25"H</p>
---	--	--	--	--

29" TURNED TABLE LEGS

COUNTRY FRENCH		GAELIC			ENGLISH COUNTRY	
						
01060110-1 3.75" Diam. x 29.25"H	01510110-1 5" Diam. x 29.25"H	01590122-1 3.5" Diam. x 29"H	01590124-1 4.5" Diam. x 29"H	01590127-1 6" Diam. x 29"H	01000110-1 3.75" Diam. x 29.25"H	01210110-1 5" Diam. x 29.25"H

MOUNTING PLATES FOR 5/16-18" HANGER BOLTS

11-DEGREE ANGLE MOUNTING PLATE	STRAIGHT MOUNTING PLATE	HEAVY DUTY PLATE
		
01ANGLEPLATE 2.375" SQ x .286" T	01STRAIGHTPLATE 2.375" SQ x .286" T	01HDPLATE 4.151" x 5.469" x .286" T

Check our price list or website for product species available per product.

POSTS & LEGS

AK:
Red Oak

AL:
Alder

CH:
Cherry

HM:
Hard Maple

HK:
Hickory

PT:
Paint Grade

WK:
White Oak

WL:
Walnut

34.5" - 36.5" SQUARE ISLAND POSTS

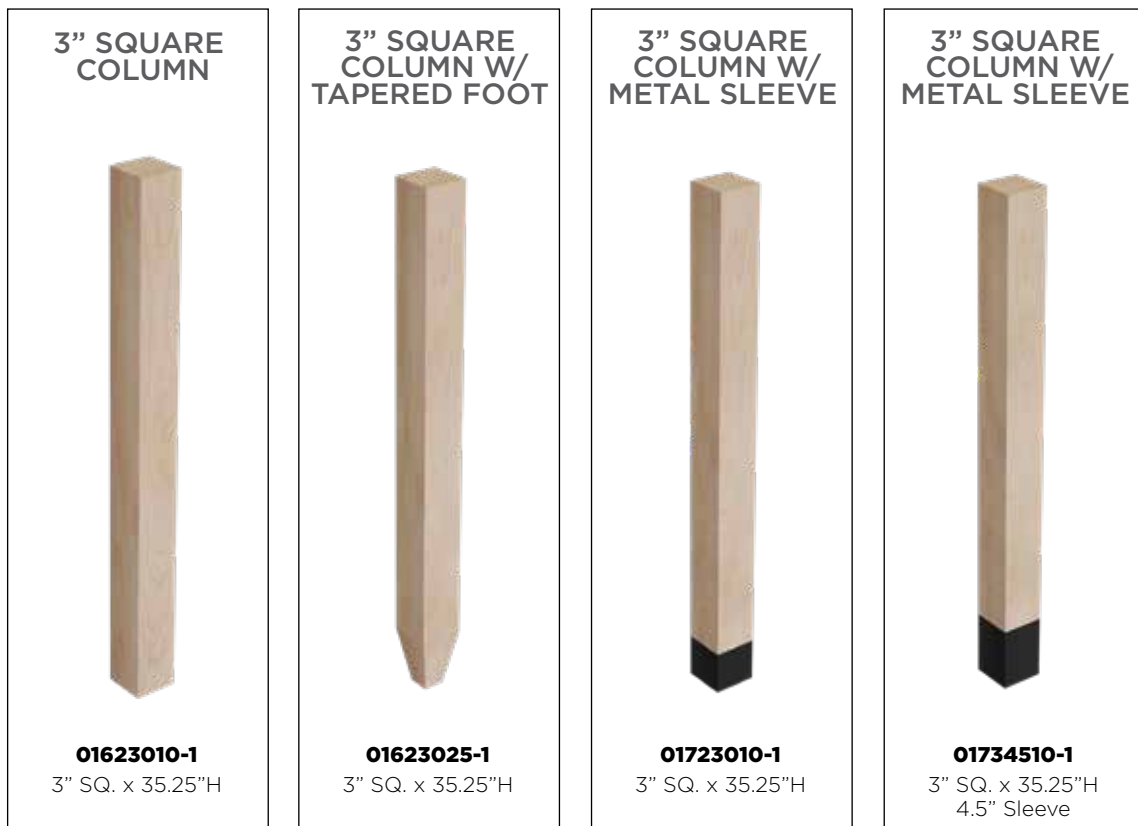
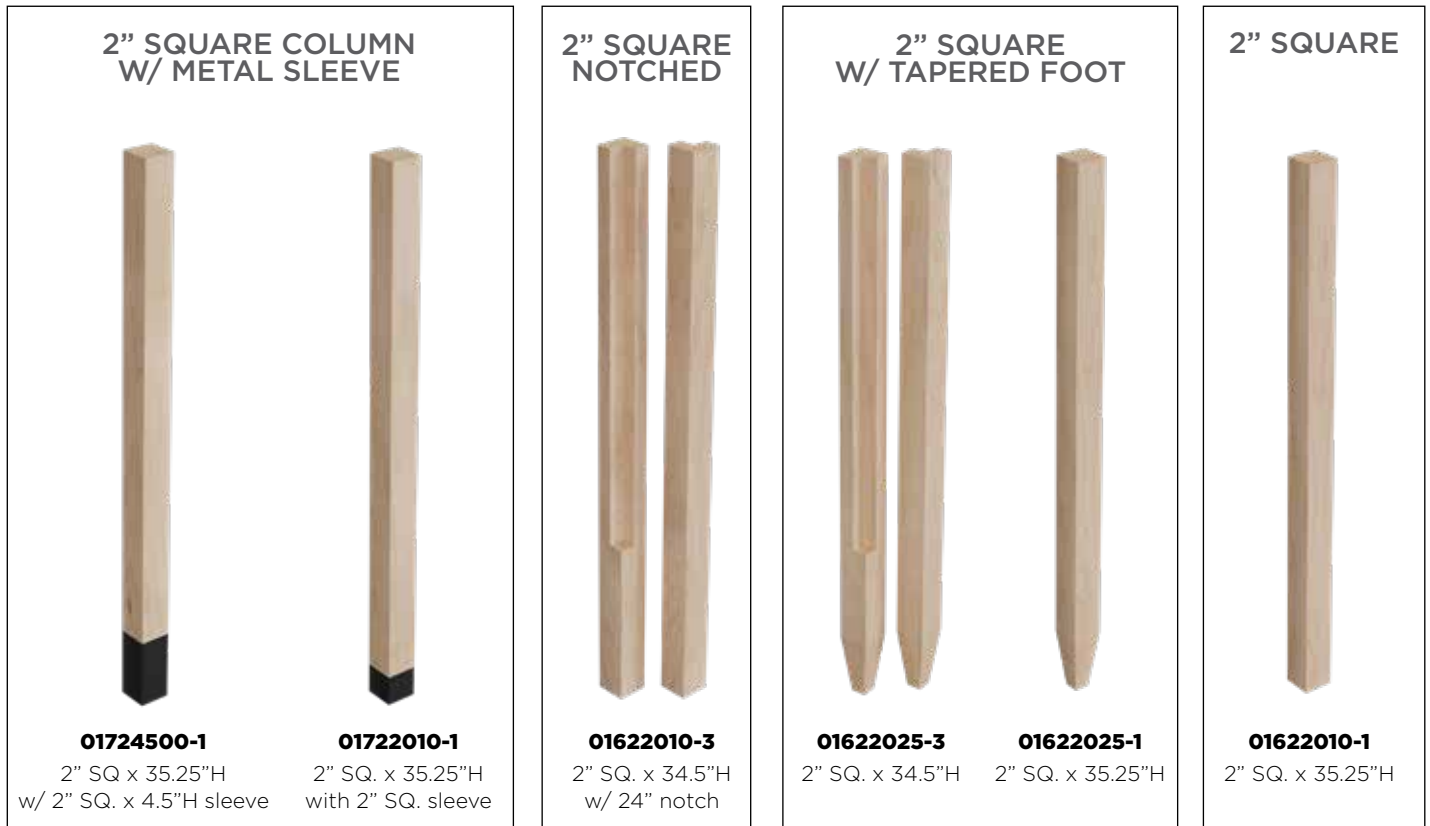

34.5" - 36.5" SQUARE ISLAND POSTS

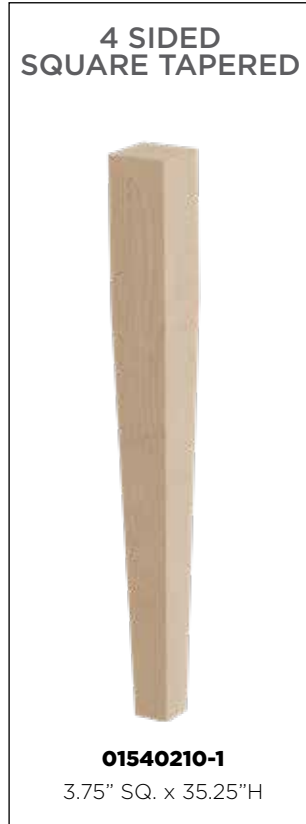

Check our price list or website for product species available per product.

POSTS & LEGS

AK:

Red Oak

AL:

Alder

CH:

Cherry

HM:

Hard Maple

HK:

Hickory

PT:

Paint Grade

WK:

White Oak



WL:

Walnut

34.5" - 36.5" ISLAND POSTS



34.5" - 36.5" ISLAND POSTS

<p>ENGLISH COUNTRY</p>  <p>01000210-1 01210210-1 3.75" SQ. x 35.25"H 5" SQ. x 35.25"H</p>	<p>ENGLISH COUNTRY DOUBLE SQUARE</p>  <p>01030210-1 3.75" SQ. x 35.25"H</p>	<p>SUMTER DOUBLE SQUARE</p>  <p>01470210-1 5" SQ. x 35.25"H</p>	<p>COUNTRY FRENCH DOUBLE SQUARE</p>  <p>01410210-1 5" SQ. x 35.25"H</p>
---	--	---	--

GAELIC



01590222-1 **01590224-1** **01590227-1**
3.5" SQ. x 34.5"H 4.5" SQ. x 35.5"H 6" SQ. x 35.5"H

GAELIC - ROUTED



01590223-1 **01590225-1** **01590228-1**
3.5" SQ. x 34.5"H 4.5" SQ. x 35.5"H 6" SQ. x 35.5"H

Check our price list or website for product species available per product.

POSTS & LEGS

AK:
Red Oak

AL:
Alder

CH:
Cherry

HM:
Hard Maple

HK:
Hickory

PT:
Paint Grade

WK:
White Oak

WL:
Walnut

34.5" - 36.5" ISLAND POSTS

IONIC ACANTHUS



01520223-1
6" SQ. X 35.25"H

WRIGHT



01040270-1
3.5" SQ. x 35.25"H

WRIGHT W/
DETACHABLE FOOT



Detaches

01040275-1
3.5" SQ. x 35.25"H

KENSINGTON



01110210-1
3" SQ. x 35.25"H

ESTATE SQUARE



01042760-1
2.75" SQ. x 35.25"H



01040260-1
3.75" SQ. x 35.25"H



01220260-1
5" SQ. x 35.25" H

NOUVEAU



01250210-1
3.5" SQ. x 35.25"H

BUNGALOW



01510228-1
3" SQ. x 34.5"H



01515028-1
5" SQ. x 34.5"H

34.5" - 36.5" ISLAND POSTS



Check our price list or website for product species available per product.

POSTS & LEGS

AK:
Red Oak

AL:
Alder

CH:
Cherry

HM:
Hard Maple

HK:
Hickory

PT:
Paint Grade

WK:
White Oak

WL:
Walnut

34.5" - 36.5" ISLAND POSTS

APEX



01570217-1

3.5" SQ. x 34.5"H

PALLADIAN



01580217-1

3.5" SQ. x 34.5"H

ROMAN CLASSIC



01082710-1

2.75" SQ. x
35.25"H

01080210-1

3.75" SQ. x
35.25"H

01230210-1

5" SQ. x
35.25"H

ROMAN CLASSIC WEAVED



01080270-1

3.75" SQ. x
35.25"H

ROMAN CLASSIC FLUTED



01082740-1

2.75" SQ. x
35.25"H

01080240-1

3.75" SQ. x
35.25"H

01230240-1

5" SQ. x
35.25"H

ROMAN CLASSIC ROPED



01082730-1

2.75" SQ. x
35.25"H

01080230-1

3.75" SQ. x
35.25"H

01230230-1

5" SQ. x
35.25"H

TULIP



01140210-1

3.5" SQ. x 34.5"H

34.5" - 36.5" ISLAND POSTS



Check our price list or website for product species available per product.

POSTS & LEGS

AK:
Red Oak

AL:
Alder

CH:
Cherry

HM:
Hard Maple

HK:
Hickory

PT:
Paint Grade

WK:
White Oak

WL:
Walnut

41"- 42.25" BAR POSTS

NOUVEAU



01250310-1
5.5" SQ. x 41"H

BUNGALOW



01510328-1
3" SQ. x 42.25"H

2" SQUARE



01632010-1
2" SQ. x 42.25"H

3" SQUARE



01633010-1
3" SQ. x 42.25"H



01733010-1
3" SQ. x 42.25"H
w/ 3" SQ. sleeve

4" SQUARE



01734010-1
4" SQ. x 42.25"H
w/ 4" SQ. sleeve



01634010-1
4" SQ. x 42.25"H

5" & 6" SQUARE



01735010-1
5" SQ. x 42.25"H w/
5" SQ. sleeve



01635010-1
5" SQ. x 42.25"H



01636010-1
6" SQ. x 42.25"H

40.5" - 42.25" BAR POSTS



Check our price list or website for product species available per product.

POSTS & LEGS

AK:
Red Oak

AL:
Alder

CH:
Cherry

HM:
Hard Maple

HK:
Hickory

PT:
Paint Grade

WK:
White Oak

WL:
Walnut



<https://bit.ly/EndPanels-Bases>



END PANELS & BASES

Image: Hardwood X-Panel

X-PANELS

TRIMMABLE HARDWOOD X-PANELS

Features 7.5" Trimmable Bottom



01XPN3025LNG-1
25"W x 3"T
x 34.5"H



01XPN3036LNG-1
36"W x 3"T
x 34.5"H



01XPN1525LNG-1
25"W x 1.5"T
x 34.5"H



01XPN1536LNG-1
36"W x 1.5"T
x 34.5"H

HARDWOOD X-PANELS



01XPNL3025-1
25"W x 3"T
x 34.5"H



01XPNL3036-1
36"W x 3"T
x 34.5"H



01XPNL1525-1
25"W x 1.5"T
x 34.5"H



01XPNL1536-1
36"W x 1.5"T
x 34.5"H

Check our price list or website for species available for product.

END PANELS & BASES

AK:
Red Oak

AL:
Alder

CH:
Cherry

HM:
Hard Maple

WK:
White Oak

WL:
Walnut

X-PANELS

TRIMMABLE HARDWOOD X-PANELS WITH BACKERS

Features 7.5" Trimmable Bottom



01XPN3025LNG-4
25"W x 3"T
x 34.5"H



01XPN3036LNG-4
36"W x 3"T
x 34.5"H



01XPN1525LNG-4
25"W x 1.5"T
x 34.5"H



01XPN1536LNG-4
36"W x 1.5"T
x 34.5"H

HARDWOOD X-PANELS BACKERS



01XPNL3025-4
25"W x 3"T
x 34.5"H



01XPNL3036-4
36"W x 3"T
x 34.5"H



01XPNL1525-4
25"W x 1.5"T
x 34.5"H



01XPNL1536-4
36"W x 1.5"T
x 34.5"H



Please note:
Backer and panel
ship unattached

STEEL BASES



PEDESTAL BASES



Check our price list or website for species available for product.

END PANELS & BASES

AK:
Red Oak

AL:
Alder

CH:
Cherry

HM:
Hard Maple

WK:
White Oak

WL:
Walnut

RADIUSED BASES



Image: Radiused Base with Toe Kick

NEW!

RADIUSED BASE WITH TOE KICK

RADIUSED BASE WITHOUT TOE KICK



01RADTBS2534-1
25"W x 9"D x 34.5"H
w/4.5" Toe Kick Base

01RADTBS3634-1
36"W x 9"D x 34.5"H
w/4.5" Toe Kick Base



01RADBS2534-1
25"W x 9"D x 34.5"H

01RADBS3634-1
36"W x 9"D x 34.5"H

Custom Sizes Available.

KITCHEN ISLAND EXTENSION BASES

Expand both the function and style of your kitchen with our new Kitchen Island Extension Bases. Available in three versatile shapes, these extensions are designed to complement a variety of design styles. Each piece is built with solid hardwood ends for lasting strength and MDF sides for stability, ensuring durability. Easily customizable with your choice of veneer or beaded panels, these extensions allow you to create a seamless look that enhances cabinetry while adding practical workspace or seating.



BASE SHAPE KITS

Kits Include: (1) Base shape, (2) Hardwood Mounting Plates or End Plugs, *(2) pcs Tambour, and (1) Cutting Template.
*See price list/website for available tambour options.



Check our price list or website for species available for product.

END PANELS & BASES

HM:
Hard Maple

MDF:
Medium Density
Fiberboard

WK:
White Oak

WL:
Walnut

HARDWOOD ISLAND PANELS WITH REMOVABLE CENTERS

Our new hardwood island end panels are designed to bring both flexibility and craftsmanship to kitchen and furniture design. Each panel features a removable center section that allows for easier finishing and unlimited customization. The center panels can be replaced with a variety of materials—including beaded wood, leather, resin, or other decorative inserts—making it simple to tailor the look to match any style or design theme. Call for custom panel quotes.



Image: Short Frame End Panel

NEW!

END PANEL: SHORT FRAME



01EPS3025-1
25"W x 3"T x 34.5"H
01EPS3036-1
36"W x 3"T x 34.5"H

END PANEL: TALL FRAME



01EPT1525-1
25"W x 1.5"T x 34.5"H
01EPT1536-1
36"W x 1.5"T x 34.5"H
01EPT3025-1
25"W x 3"T x 34.5"H
01EPT3036-1
36"W x 3"T x 34.5"H

END PANEL: ARCH



01EPAR1525-1
25"W x 1.5"T x 34.5"H

FURNITURE & BUN FEET

Image: Round Tapered Legs



SPECIALTY FEET

HAND CARVED CENTER PEDESTAL



01708310-1
16"W X 2.5"H

HAND CARVED CORNER PEDESTAL



01708010-1
8.25"W x 8.25"W x 4"H

HAND CARVED
LEFT & RIGHT PEDESTAL SET



SOLD AS A 2-PC SET
01708110-1
8.25"W x 4"H

HAMPTON LEFT



01703110-1
6"W x 4.5"H x 1.5"T

HAMPTON CORNER



01703010-1
4.5"H x 1.5"T x 6"L x 6"L

HAMPTON RIGHT



01703210-1
6" W x 4.5" H x 1.5" T

CARVED BUN FEET

BELLA SMOOTH



01707410-1
3.75" DIAM. x 8"H

BELLA FLUTED



01707440-1
3.75" DIAM. x 8"H

SCROLL



01709010-1
3.25"D. x 3.25"W x 4.5"H

ACANTHUS CORNER



01707710-1
3.375" SQ. x 4.5"H



Image: 9" Round Tapered Foot

Check our price list or website for species available for product.

FURNITURE & BUN FEET

AK:
Red Oak

AL:
Alder

CH:
Cherry

HM:
Hard Maple

HK:
Hickory

PT:
Paint Grade

WK:
White Oak

WL:
Walnut

SQUARE TURNED BUN FEET

NOUVEAU



01700457-1
4" SQ. x 4"H

01700459-1
3.25" SQ. x 4"H

METRO



01705710-1
4" SQ. x 4.5"H

TULIP SQUARE



01706065-1
3.5" SQ. x 4.625"H

SUMMIT



01705080-1
4" SQ. x 4.5"H

LILLE SQUARE



01750460-1
4" SQ. x 4"H

01704060-1
4" SQ. x 4.5"H

EMPIRE



01700146-1
3" SQ. x 4.5"H

KENSINGTON



01703510-1
3" SQ. x 4.5"H

LIAM



01700627-1
4.62" SQ. x 6"H

SQUARE COLUMN BASE



01705860-1
6" SQ. x 4.5"H

SHAKER



01705715-1
4.5" SQ. x 4.5"H

SQUARE & SQUARE TAPERED FURNITURE & BUN FEET

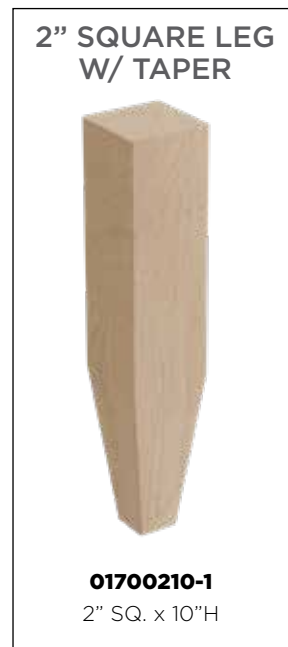
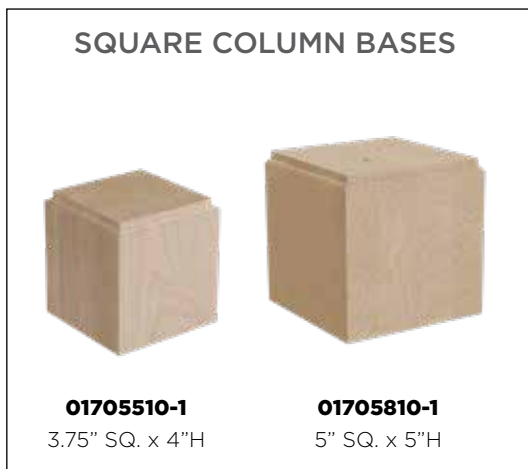

Check our price list or website for species available for product.

FURNITURE & BUN FEET

AK:
Red Oak

AL:
Alder

CH:
Cherry

HM:
Hard Maple

HK:
Hickory

PT:
Paint Grade

WK:
White Oak

WL:
Walnut

TOE KICK FEET

TULIP



01706060-1

4"W x 2.5"T x 4.625"H

PALLADIAN



01700018-1

4"W x 2.5"T x 4.5"H

APEX



01705155-1

2.5" SQ. x 4"H



01705150-1

2.75" SQ. x 4"H

TOE KICK FEET W/ 4.5" METAL SLEEVE



01700245-1

01700245-6

2" SQ. x 4.5"H



01700345-1

01700345-6

3" SQ. x 4.5"H

(-6): includes a pre-installed 5/16-18 hanger bolt protruding .75"



Image: Apex Toe Kick

ROUND TURNED BUN FEET

CLASSIC



01705310-1

3.625" DIAM. x 4.5"H

CRAFTSMAN



01760410-1

3.625" DIAM. x 4"H



01704210-1

3.625" DIAM. x 4.5"H

TULIP



01706010-1

3.5" DIAM. x 4.625"H

COUNTRY FRENCH



01702510-1

3.625" DIAM. x 4"H



01700015-1

3.875" DIAM. x 4.5"H

MADISON



01704110-1

3" DIAM. x 6.125"H

AIDEN



01700327-1

3.625" DIAM. x 4.5"H

LILLE



01704010-1

4" DIAM. x 4.5"H

LILLE FLUTED



01704040-1

4" DIAM. x 4.5"H

OXFORD



01704910-1

4" DIAM. x 4.5"H

Check our price list or website for species available for product.

FURNITURE & BUN FEET

AK:
Red Oak

AL:
Alder

CH:
Cherry

HM:
Hard Maple

HK:
Hickory

PT:
Paint Grade

WK:
White Oak

WL:
Walnut

6" & 9" FURNITURE FEET

(-6): Includes a pre-installed 5/16-18 hanger bolt protruding .75" (-8): Includes hanger bolt and clear coat semi-gloss finish.

ROUND TAPERED FEET W/ FERRULE



01240006-1
01240006-6
01240006-8
1.5" DIAM. x 6" H

01240009-1
01240009-6
01240009-8
1.87" DIAM. x 9" H

SQUARE TAPERED FEET W/ FERRULES



01241006-1
01241006-6
01241006-8
1.5" SQ. x 6" H

01241009-1
01241009-6
01241009-8
1.87" SQ. x 9" H

TIPTOE W/ FERRULE



01242006-1
01242006-6
01242006-8
2.75" DIAM. x 6" H

01242009-1
01242009-6
01242009-8
3.625" DIAM. x 9" H

ROUND TAPERED FEET W/ BRASS SLIPPER CUP



01221006-6
01221006-8
2" DIAM. x 6" H

01221009-6
01221009-8
2.6875" DIAM. x 9" H

SQUARE TAPERED FEET W/ BRASS SLIPPER CUP



01222006-6
01222006-8
2.625" DIAM. x 6" H

CALLA FEET W/ BRASS SLIPPER CUP



01223006-6
01223006-8
2.5" DIAM. x 6" H

01223009-6
01223009-8
2.5" DIAM. x 9" H

PERLE



01245106-1
01245106-6
01245106-8
2.25" DIAM. x 6" H

01245109-1
01245109-6
01245109-8
2.75" DIAM. x 9" H

ROUND TAPERED



01243006-1
01243006-6
01243006-8
1.5" DIAM. x 6" H

01243009-1
01243009-6
01243009-8
1.87" DIAM. x 9" H

SQUARE TAPERED



01244006-1
01244006-6
01244006-8
1.5" SQ. x 6" H

01244009-1
01244009-6
01244009-8
1.87" SQ. x 9" H

CHROME

ANGLE ROUND



01700400CR1

2.813" PLATE x 5.375"D
x 4.875"H

5" SQUARE
CORNER



01700402CR1

4" SQ. x 5"H

ROUND CORNER



01700012CR1

4.134" PLATE x 5.906"D
x 6"H

STRAIGHT
ROUND



01700905CR1

3.5" DIAM. x 4"H

SOLID BRASS

RUTLAND



01700408-1

4.969"W X 7.189"H

DEVON



01700406-1

1.44"W X 5.906"H

ESSEX



01700412-1

2"W X 5.5"H
w/3"X3" plate

TYNE



01700410-1

2.106"W X 5.875"H
w/2" plate

4" APEX



01704017-1

3.75"W X 4"H

APEX VASA



01706018-1

4.724"W X 5.906"H

BRISTOL

(Made of steel)



01700401WR1

1.17"W X 6.18"H
w/4x4 plate

Check our price list or website for finishes available.

FURNITURE & BUN FEET

AB:
Antique Brass

CR:
Chrome

PB:
Polished Brass

SB:
Satin Brass

WR:
Flat Black

ALUMINUM SLEEVES AND FERRULES

SQUARE ALUMINUM FERRULES

Pictured in Brushed Aluminum

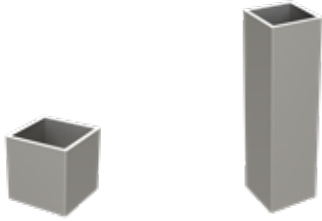

01FRS1010-1

1" SQ. OUTER DIM.
x .125"T x 1"H

01FRS1254-1

1.25" SQ. OUTER DIM.
x .125"T x 4"H

ROUND ALUMINUM FERRULES

Pictured in Brushed Aluminum



01FRC1010-1

.913" OUTER DIAM.
x .125"T x 1"H

01FRC1040-1

.913" OUTER DIAM.
x .125"T x 4"H

TOE KICK ALUMINUM SLEEVES

Pictured in Chrome



01SLV245-1

2" SQ. OUTER DIM.
x .125"T x 4.5"H

01SLV345-1

3" SQ. OUTER DIM.
x .125"T x 4.5"H

ALUMINUM SLEEVES



01SLV2-1

2" SQ. OUTER DIM.
x .125"T x 2"H



01SLV3-1

3" SQ. OUTER DIM.
x .125"T x 3"H



01SLV4-1

4" SQ. OUTER DIM.
x .125"T x 4"H



01SLV5-1

5" SQ. OUTER DIM.
x .125"T x 5"H
BA & WR Only

BA:
Brushed
Aluminum

CR:
Chrome

GL:
Soft Gold

PB:
Polished Brass

SB:
Satin Brass

ST:
Satin Stainless

WB:
Warm Bronze

WR:
Flat Black

BRASS SLIPPER CUPS

SOLID BRASS SLIPPER CUPS

Pictured in Chrome



01SLPR106-1

1.59" SQ. X 1.89"H



01SLPR105-1

1.26" DIAM. X 2.165"H



01SLPR104-1

1.154" DIAM. X 1.87"H

FURNITURE & BUN FEET Check our price list or website for finishes available for product.

AB:
Antique Brass

CR:
Chrome

PB:
Polished Brass

SB:
Satin Brass

WR:
Flat Black



<https://bit.ly/Brackets-Corbels>



BRACKETS & CORBELS

Image: Lexington Bar Bracket & Gallery Rail

BRACKETS

NEW! BRASS BRACKETS
Knurled & Plain Styles Available



01NARCHKNLD75-1
Knurled
7.5"D X 10"H X 1"W

01WARCHKNLD75-1
Knurled
7.5"D X 10"H X 1"W

01WARCHPLN75-1
7.5"D X 10"H X 1"W

01NARCHPLN75-1
7.5"D X 10"H X 1"W

Knurled Texture

BAUHAUS BRACKETS
Check Website for Arch Finishes



01600016-1
2.125"W x 9"D x 12"L

01600006-1
2.125"W x 7"D x 9"L

MID-CENTURY TRIANGLE BRACKET
Check Website For Finishes



01651270-1
.75"W X 12.625"D X 6.875"H

BRACKETS

LEXINGTON BAR BRACKETS



01605006-1
2.5"W x 10"D x 5"L



01605007-1
1.5"W x 10"D x 5"L



01605008-1
2.5"W x 10"D x 7.5"L



01605009-1
1.5"W x 10"D x 7.5"L

CONTOUR BRACKET



01600300-1
2.5" W x 9" D x 9" L

ARTS & CRAFTS BRACKET



01607012-1
5" W x 7.5" D x 11.5" L

Check our price list or website for species available for product.

BRACKETS & CORBELS

AK:
Red Oak

AL:
Alder

CH:
Cherry

HM:
Hard Maple

HK:
Hickory

PT:
Paint Grade

WK:
White Oak

WL:
Walnut

CORBELS

NEW! CONTEMPORARY CORBELS WITH METAL* / LEATHER* ACCENTS

*See website for available insert options



01600001-1

3"W x 6"D x 12"L



01600002-1

4.5"W x 18"D x 12"L



01600003-1

4.5"W x 8"D x 34.5"L

PORTRAIT CORBEL



01600009-1

3" W x 8" D x 12" L

TRIAD CORBELS-NARROW



01607009-1

2.875" W x 9" D x 12" L



01607008-1

2.875" W x 7" D x 9" L

TRIAD CORBELS



01607006-1

7.5" W x 6" D x 8.375" L



01607007-1

3.75" W x 4" D x 5.5" L

CORBELS

PLAIN NOUVEAU CORBELS



01601400-1

5.5" W x 9" D x 13" L



01601300-1

5.5" W x 2.75" D x 13" L



01601100-1

3.5" W x 3.875" D x 6.831" L

SIMPLICITY CORBELS



01607004-1

5.5" W x 6.875" D x 7.5" L



01607001-1

4.5" W x 5.75" D x 5" L



01607005-1

3.5" W x 4.125" D x 4.5" L

Check our price list or website for species available for product.

BRACKETS & CORBELS

AK:
Red Oak

AL:
Alder

CH:
Cherry

HM:
Hard Maple

HK:
Hickory

PT:
Paint Grade

WK:
White Oak

WL:
Walnut

CORBELS

APEX CORBELS



01607117-1

3"W X 3.875"D X 7"L

01607217-1

3.875" W x 5" D x 8.75" L

01607317-1

6" W x 8" D x 14" L

REVIVAL CORBELS



01604510-1

3.75" W x 9" D x 14" L

01604505-1

3.75" W x 9" D x 9" L

SHAKER CORBELS



01606002-1

3.875" W x 3.5" D x 6.75" L

01606001-1

5.25" W x 6.75" D x 13.25" L

01606003-1

6.625" W x 7.5" D x 16" L

CORBELS

CRAFTSMAN CORBELS



01608009-1
2.75" W x 6" D x 10" L



01608007-1
1.5" W x 8" D x 12" L



01608010-1
3.5" W x 8" D x 12" L



01608008-1
3.5" W x 8" D x 12" L

PETITE CRAFTSMAN CORBEL



01608001-1
1.25" W x 1.5" D x 3" L

MISSION CORBELS



01601205-1
5.75" W x 3.875" D x 9" L



01601204-1
3.5" W x 3.5" D x 13" L



01601203-1
3.5" W x 9" D x 13" L

Check our price list or website for species available for product.

BRACKETS & CORBELS

AK:
Red Oak

AL:
Alder

CH:
Cherry

HM:
Hard Maple

HK:
Hickory

PT:
Paint Grade

WK:
White Oak

WL:
Walnut

CORBELS

ARTS & CRAFTS CORBELS



01607010-1

4.5" W x 7.5" D x 14" L



01607011-1

3.75" W x 5.813" D x 9" L

PINNACLE CORBELS



01607316-1

9" W x 7.25" D x 12" L



01607216-1

5.5" W x 5" D x 8" L

HAND CARVED GRAPE CORBELS



01901005-1

5.5" W x 7" D x 15" L



01901003-1

3.5" W x 8" D x 13" L

MADLINE CORBELS



01607315-1

4" W x 9.5" D x 14" L



01607215-1

2.5" W x 6.125" D x 8" L

CORBELS

ACANTHUS CORBELS

01901105-1
3.5" W x 8" D x 13" L

01901001-1
7.875" W x 6" D x 14.5" L

01901002-1
5" W x 4.5" D x 12" L

ACANTHUS CORBELS

01901108-1
6.5" W x 2.5" D x 15" L

01901107-1
3" W x 1.323" D x 6" L

01901009-1
3" W x 1.75" D x 4.5" L
SOLD AS 2-PC SET

GAELIC CORBELS

01600928-1
4.75" W x 5.75" D x 9" L

01600628-1
3.5" W x 3.875" D x 6.625" L

Check our price list or website for species available for product.

BRACKETS & CORBELS

AK:
Red Oak

AL:
Alder

CH:
Cherry

HM:
Hard Maple

HK:
Hickory

PT:
Paint Grade

WK:
White Oak

WL:
Walnut

CORBELS

CORINTHIAN CORBELS



01605001-1

4.75" W x 5.5" D x 9.625" L



01605000-1

3.875" W x 3" D x 8" L



01605005-1

3.5" W x 7" D x 14" L

CORINTHIAN CORBELS



01904991-1

3.75" W x 8.5" D x 13" L



01904990-1

2.625" W x 2.5" D x 4.5" L



01901004-1

5.25" W x 4.5" D x 12.5" L



01904993-1

3.75" W x 8.5" D x 13" L

CORBELS

CELTIC CORBELS



01601427-1

5.5" W x 7.125" D x 14" L

01600927-1

4.75" W x 5.75" D x 9.5" L

01600627-1

3.5" W x 3.875" D x 6.625" L

PALLADIAN CORBEL



01600318-1

3" W x 3.875" D x 7" L



Image: Mid-Century Triangle Bracket w/ Flat Shelves

Check our price list or website for species available for product.

BRACKETS & CORBELS

AK:
Red Oak

AL:
Alder

CH:
Cherry

HM:
Hard Maple

HK:
Hickory

PT:
Paint Grade

WK:
White Oak

WL:
Walnut

<https://bit.ly/CAC-Mouldings>



CREATE-A-COLUMN™ HALF ROUND MOULDINGS & RADIUS CORNER MOULDINGS

Image: Plain Half Round Moulding - Series 150

NEW! RADIUSED CORNER MOULDINGS

Add elegance and dimension to your cabinetry and furniture with our Radiused Corner Mouldings. Featuring softly curved lines inspired by Art Deco design, these mouldings bring a refined, detail to any project. Crafted from high-quality hardwood or MDF, they are supplied unfinished, ready to be painted or veneered.



2" RADIUS



01RADCRN248-1
2.366" X 2.366" X 48"
01RADCRN296-1
2.366" X 2.366" X 96"

3" RADIUS



01RADCRN348-1
3.394" X 3.394" X 48"
01RADCRN396-1
3.394" X 3.394" X 96"

4" RADIUS



01RADCRN448-1
5.462" X 5.462" X 48"
01RADCRN496-1
5.462" X 5.462" X 96"

6" RADIUS



01RADCRN648-1
6.389" X 6.389" X 48"
01RADCRN696-1
6.389" X 6.389" X 96"

Check our price list or website for product species availability. **CREATE-A-COLUMN™**

AL:
Alder

AK:
Red Oak

CH:
Cherry

HM:
Hard Maple

MDF:
Medium Density
Fiberboard

QS:
Quarter Sawn
White Oak

WK:
White Oak

CREATE-A-COLUMN™ & HALF ROUND MOULDINGS

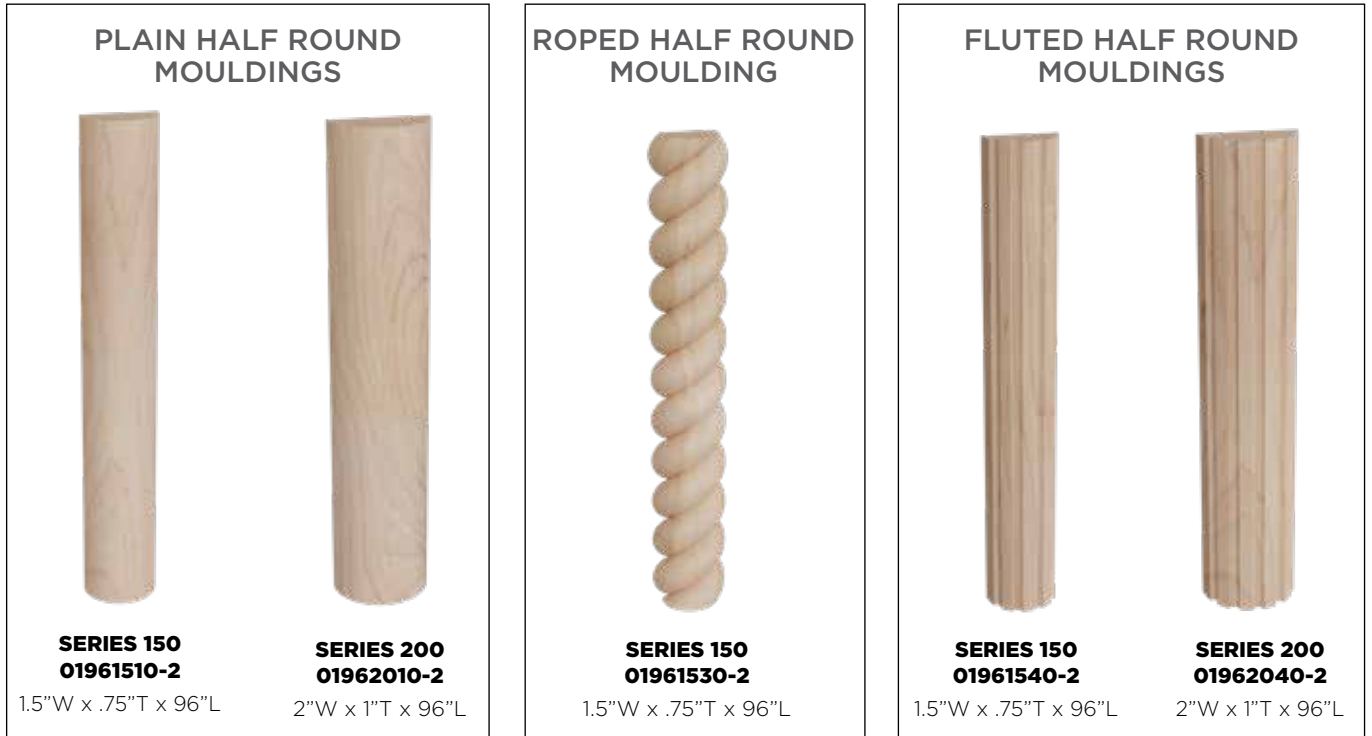

Series 150 are 1.5" Half Round Mouldings to fit spaces 2.5" or wider.
Series 200 are 2" Half Round Mouldings to fit spaces 3" or wider.



CREATE-A-COLUMN™ & HALF ROUND MOULDINGS

150 COMBO SPINDLE
For use with 1.5" half round



SERIES 150
01391510-2
2"W x .906"D x 9.438"L

CENTER SPINDLES



For use with 1.5" half round

SERIES 150
01311510-2
2.125"W x 1"D x 3"L

For use with 2" half round

SERIES 200
01312010-2
2.875"W x 1.3"D x 3.5"L

END BLOCKS



For use with 1.5" spindle

SERIES 150
01331510-2
2.5"W x 1.19"D x 5.75"L

For use with 2" spindle

SERIES 200
01332010-2
3"W x 1.4"D x 5.75"L

END SPINDLES



For use with 1.5" half round

SERIES 150
01321510-2
2.5"W x 1"D x 3"L

For use with 2" half round

SERIES 200
01322010-2
3"W x 1.5"D x 3.5"L

Check our price list or website for species available for product.

CREATE-A-COLUMN™

AK:
Red Oak

AL:
Alder

CH:
Cherry

HK:
Hickory

HM:
Hard Maple

DECORATIVE MOULDINGS & PILASTERS

Image: Hardwood Shiplap Decorative Moulding



<https://bit.ly/Mouldings-Pilasters>



DECORATIVE MOULDINGS

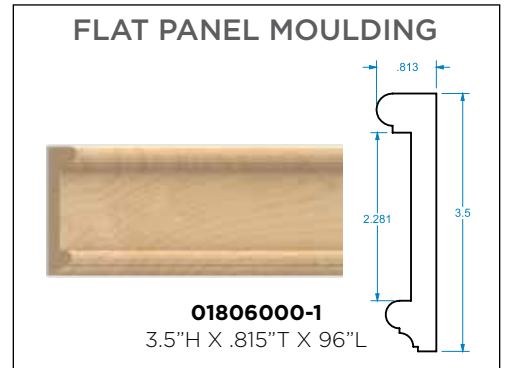
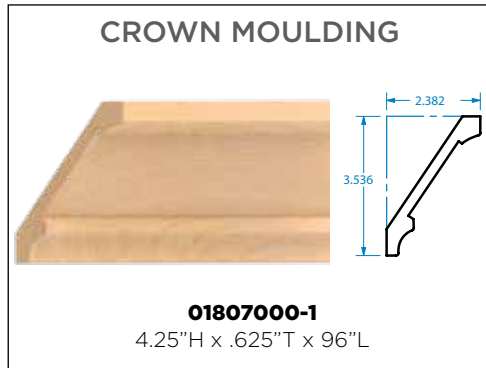
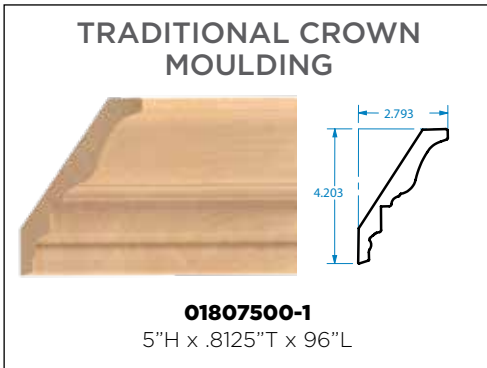
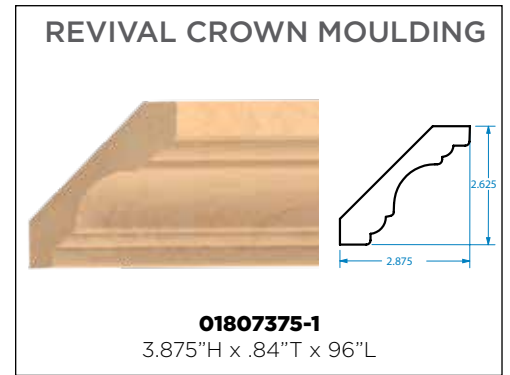

LIGHT RAIL MOULDINGS

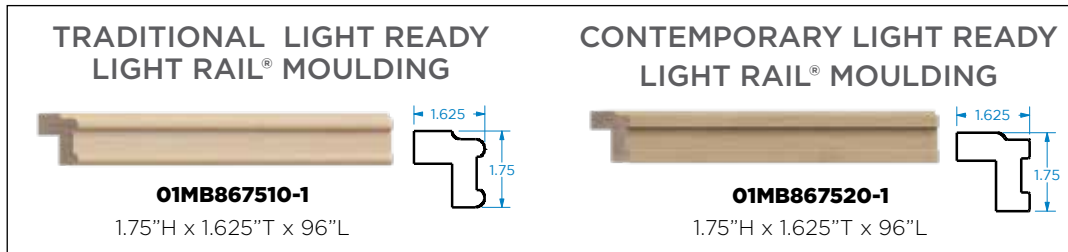

PILASTERS

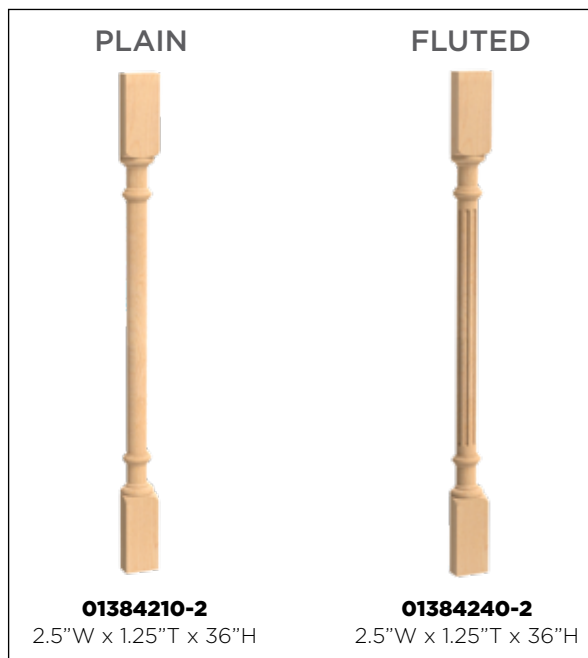

SHELVING

Image: Contemporary Floating Shelving



<https://bit.ly/Shelves-SupportBrackets>

FLOATING SHELVING

Our floating shelves include hidden shelf supports.
Hidden shelf supports can be purchased separately for use in your custom projects.

CONTEMPORARY FLOATING CORNER SHELVES W/ HIDDEN STEEL SUPPORT



01MFL102424-1

10" D x 2.5" T x 24" Each Way

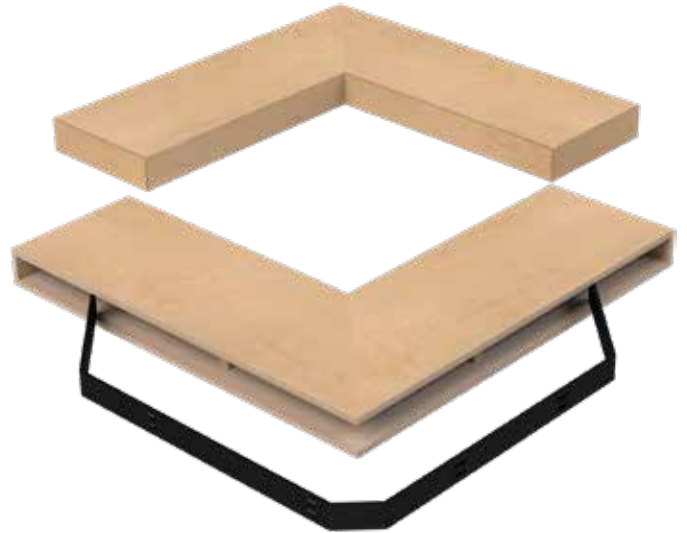

01MFL103030-1

10" D x 2.5" T x 30" Each Way

CONTEMPORARY FLAT CORNER SHELVES



01MSH122424-1

12" D x .75" T x 24" Each Way



01MSH123030-1

12" D x .75" T x 30" Each Way

CONTEMPORARY FLOATING LINEAR SHELVES W/ HIDDEN STEEL SUPPORT



01MFL102410-1

10" D x 2.5" T x 24" L



01MFL103610-1

10" D x 2.5" T x 36" L

Custom sizes available!

Check our price list or website for species available for product.

SHELVING

AK:
Red Oak

AL:
Alder

CH:
Cherry

HM:
Hard Maple

HK:
Hickory

PT:
Paint Grade

WK:
White Oak

WL:
Walnut

BRACKETS, STRAPS, CHANNEL SHELVING



SLIMLINE CHANNEL SHELF

- 01CHSHLF0424-1**
2.75" H x 24" W x 5.125" D
- 01CHSHLF0436-1**
2.75" H x 36" W x 5.125" D
- 01CHSHLF0448-1**
2.75" H x 48" W x 5.125" D
- 01CHSHLF0460-1**
2.75" H x 60" W x 5.125" D

Includes leveler & walldog screws.

SLIMLINE CHANNEL SHELF - ALUMINUM



- 01CHSHLF0424-1**
2.5" H x 24" W x 4.125" D
- 01CHSHLF0436-1**
2.5" H x 36" W x 4.125" D
- 01CHSHLF0448-1**
2.5" H x 48" W x 4.125" D

DEEP SLIMLINE CHANNEL SHELF - ALUMINUM



- 01CHSHLF0624-1**
2.5" H x 24" W x 6.125" D
- 01CHSHLF0636-1**
2.5" H x 36" W x 6.125" D
- 01CHSHLF0648-1**
2.5" H x 48" W x 6.125" D

Includes leveler & walldog screws.

TEXTURED FLOATING SHELF W/ HIDDEN STEEL SUPPORT



- 01FL102410-1**
10" D x 2.5" T x 24" W
- 01FL103610-1**
10" D x 2.5" T x 36" W

CORNER FLOATING SHELF - HAND SCRAPPED



- 01FL103030-1**
10" D x 2.5" T x 30" W

FLOATING SHELF & SUPPORT BRACKETS

HIDDEN CORNER SHELF SUPPORTS



01981515WR1
21.718" W Each Way x 1.65" H
For use with 24" x 24" corner shelf.

01982222WR1
28.75" W Each Way x 1.75" H
For use with 30" x 30" corner shelf.

9" HIDDEN SHELF SUPPORT



01980109WR1
9.75" W x 8" D x 1.75" H
For use with any 10"D X 2"T floating shelf.

16" HIDDEN SHELF SUPPORT



01980116WR1
16" W x 8" D x 1.75" H
For use with any 10"D X 2"T floating shelf.

22.5" HIDDEN SHELF SUPPORT



01981022WR1
22.25" W x 8" D x 1.75" H
For use with any 10"D X 2"T floating shelf.



<https://bit.ly/Outlets-Vents>



OUTLETS & VENTS

Image: Linear Style Toe Kick Vent

OUTLET COVERS

SINGLE OUTLET	DOUBLE OUTLET
	
01450002-1 3.5"W x .375"T x 5.75"H	01451002-1 5.5"W x .375"T x 5.75"H

SINGLE ROCKER	DOUBLE ROCKER	TRIPLE ROCKER	QUAD ROCKER
			
01450003-1 3.5"W x .375"T x 5.75"H	01451003-1 5.5"W x .375"T x 5.75"H	01453003-1 7.313"W x .375"T x 5.75"H	01454003-1 9.125"W x .375"T x 5.75"H

SINGLE SWITCH	DOUBLE SWITCH	TRIPLE SWITCH	QUAD SWITCH
			
01450001-1 3.5"W x .375"T x 5.75"H	01451001-1 5.5"W x .375"T x 5.75"H	01453001-1 7.313"W x .375"T x 5.75"H	01454001-1 9.125"W x .375"T x 5.75"H

Check our price list or website for species available for product.

FINISHING TOUCHES

AK: Red Oak

AL: Alder

CH: Cherry

HM: Hard Maple

WL: Walnut

WK: White Oak

OUTLET COVERS

SWITCH COMBO 1



01450012-1

5.5"W x .375"T x 5.75"H

SWITCH COMBO 2



01451012-1

7.313"W x .375"T x 5.75"H

SWITCH COMBO 3



01450013-1

5.5"W x .375"T x 5.75"H

SWITCH COMBO 4



01451013-1

7.313"W x .375"T x 5.75"H

SINGLE BLANK
SWITCH PLATE COVER



01452001-1

3.5"W x .375"T x 5.75"H

DOUBLE BLANK
SWITCH PLATE COVER



01452002-1

5.5"W x .375"T x 5.75"H

ELECTRICAL BOX ROUTING

Let your kitchen island design speak for itself with an integrated electrical outlet.

We offer Electrical Box Routing and Electrical Boring to most columns greater than 3"W. Electrical Box Routing allows you to install electrical components directly into the column. For additional electrical wiring, we can bore a ½" hole through the entire length of the column.

AVAILABLE FOR MOST COLUMNS.
EMAIL FOR AVAILABILITY.



<https://bit.ly/ElectricalBox-OrderForm>

TOE KICK VENT

GRATE STYLE TOE KICK VENTS

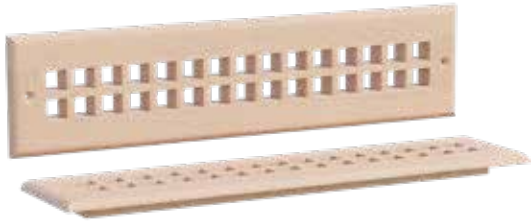

01992114-1
15.75"W x .75"T x 3.75"H



01992110-1
11.75"W x .75"T x 3.75"H

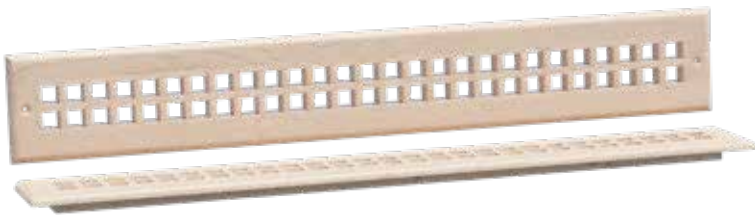

01992124-1
25.75"W x .75"T x 3.75"H



01992112-1
13.75"W x .75"T x 3.75"H

LINEAR STYLE TOE KICK VENTS



01992214-1
15.75"W x .75"T x 3.75"H



01992224-1
25.75"W x .75"T x 3.75"H



01992210-1
11.75"W x .75"T x 3.75"H



01992212-1
13.75"W x .75"T x 3.75"H

Check our price list or website for species available for product.

FINISHING TOUCHES

AK: Red Oak

AL: Alder

CH: Cherry

HM: Hard Maple

WL: Walnut

WK: White Oak

TOE KICK VENT

SELF RIMMING TOE KICK VENTS



01992010-1
11.75"W x .75"T x 3.75"H



01992012-1
13.75"W x .75"T x 3.75"H



01992014-1
15.75"W x .75"T x 3.75"H



01992024-1
25.75"W x .75"T x 3.75"H

SELF RIMMING FLOOR VENTS



01994014-1
15.75"W x .75"T x 5.75"H



01994010-1
11.75"W x .75"T x 5.75"H



01994012-1
13.75"W x .75"T x 5.75"H



CUSTOM PANEL INSERTS

Image: Custom Decorative Hardwood Panel, and Beaded Tambour

NEW! CUSTOM DECORATIVE PANELS

CHOOSE YOUR MATERIAL. CHOOSE YOUR STYLE. CHOOSE YOUR PLACEMENT.

Bring your designs to life with customizable panels crafted to fit your exact vision. Whether you're designing cabinetry, furniture, or architectural accents, our panels offer limitless creative options.



Material Options (2 Panel Minimum)

- **1/8" Brass Sheets:** Luxe metallic finish for a bold, modern look.
- **1/4" MDF:** Smooth and versatile, ready to paint or finish.
- **1/4" MDF with Hardwood Veneer:** Adds natural beauty and warmth.

Customization Choices

- **Style:** Select from a variety of decorative patterns.
- **Pattern Count:** Choose how many repeats per panel.
- **Placement:** Position your design at the top, center, or bottom of the panel.

Crafting Methods

- **CNC Routed:** Clean precision with a 1/16" minimum radius.
- **Laser Cut:** Tighter, more intricate designs with darkened interior edges that create a subtle shadow effect.

Why Choose Our Panels?

- Fully customizable for your project needs.
- Available in multiple premium materials.
- Options for clean precision or artistic detailing.
- Designed for cabinetry, furniture, and architectural features.

Order form coming soon. Contact us for a quote.
Available raw or finished. Minimums and set-up fees may apply.
See Website for all material specifications.

NEW! CUSTOM METAL CABINET MULLIONS

Our Custom Mullion Program offers designers and architects unparalleled versatility for elegant custom designs. Using CNC and laser-cutting technology, each panel features customizable patterns for optimal ventilation, ideal for cabinetry, closets, mudrooms, and architectural wall accents.



Elevate Your Cabinetry with Style and Function

Our **custom metal mullions** bring sophistication and precision to cabinetry design. Perfect for high-end projects, these mullions combine elegance, functionality, and versatility.

Material & Finish Options

- **Stainless Steel:** Sleek, modern, and durable
- **Brass:** Warm, luxurious appeal
- **Finishes:** Plain, powder-coated, or clear-coated
- **Design Flexibility:** Ideal for intricate patterns and high-end design aesthetics
- Perfect for cabinetry requiring ventilation
- Delicate designs can be sandwiched between glass for a refined, custom look

Why Choose Our Metal Mullions?

- **Durable materials** suitable for long-lasting use
- Available in **multiple finishes** to match your design vision
- Perfect for creating **architectural detail** and **visual interest** in cabinetry
- Combines function with decorative appeal

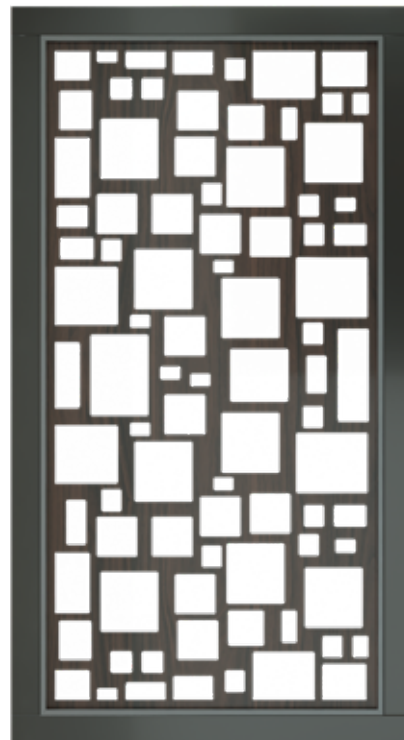

Order form coming soon. Contact us for a quote.
See website for more detail.

CUSTOM PANELS



Image: Custom Laser-Cut Metal Mullions



<https://bit.ly/Gallery-Rail>



GALLERY RAIL

Image: Double Contemporary Gallery Rail

GALLERY RAIL

Install Gallery Rail components to the tops of cabinets, furniture, shelving, spice racks, and more to create a curated look. We recommend spacing between posts across the front to be 10"– 12" apart. Manufactured from the finest quality cast brass, Gallery Rail components will not tarnish, rust, peel, or chip. Gallery Rail Sample Kits available on our website.

BRASS TRADITIONAL

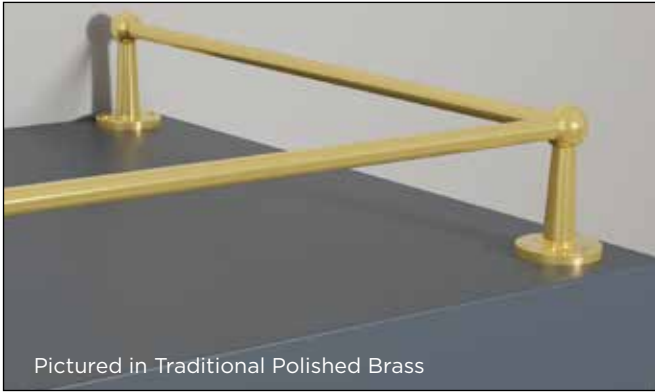

Pictured in Traditional Polished Brass

POLISHED BRASS

Corner Post: 01HC9002PB1
 .906" DIAM. x 1.575"H
Center Post: 01HC9001PB1
 .906" DIAM. x 1.575"H
End Post: 01HC9003PB1
 .906" DIAM. x 1.575"H
Rail: 01HC900436PB1
 6 mm DIAM. x 36"L



CHROME

Corner Post: 01HC9002CR1
 .906" DIAM. x 1.575"H
Center Post: 01HC9001CR1
 .906" DIAM. x 1.575"H
End Post: 01HC9003CR1
 .906" DIAM. x 1.575"H
Rail: 01HC900436CR1
 6 mm DIAM. x 36"L



FLAT BLACK

Corner Post: 01HC9002WR1
 .906" DIAM. x 1.575"H
Center Post: 01HC9001WR1
 .906" DIAM. x 1.575"H
End Post: 01HC9003WR1
 .906" DIAM. x 1.575"H
Rail: 01HC900436WR1
 6 mm DIAM. x 36"L



SATIN BRASS

Corner Post: 01HC9002SB1
 .906" DIAM. x 1.575"H
Center Post: 01HC9001SB1
 .906" DIAM. x 1.575"H
End Post: 01HC9003SB1
 .906" DIAM. x 1.575"H
Rail: 01HC900436SB1
 6 mm DIAM. x 36"L



Contemporary
Gallery Rail

GALLERY RAIL

SINGLE CONTEMPORARY

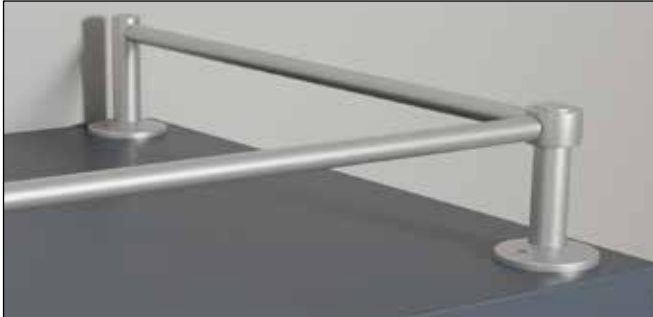

Pictured in Stainless Steel



STAINLESS STEEL

End Post: 01HC9014SS1
.906" DIAM. x 1.575" H
Center Post: 01HC9015SS1
.906" DIAM. x 1.575" H
Corner Adapter: 01HC9016SS1
1.102" DIAM. X 1.654"H
Rail: 01HC900436SS1, 6 mm Diam. x 36"L



FLAT BLACK

End Post: 01HC9014WR1
.906" DIAM. x 1.575" H
Center Post: 01HC9015WR1
.906" DIAM. x 1.575" H
Corner Adapter: 01HC9016WR1
1.102" DIAM. X 1.654"H
Rail: 01HC900436WR1, 6 mm Diam. x 36"L



SATIN BRASS

End Post: 01HC9014SB1
.906" DIAM. x 1.575" H
Center Post: 01HC9015SB1
.906" DIAM. x 1.575" H
Corner Adapter: 01HC9016SB1
1.102" DIAM. X 1.654"H
Rail: 01HC900436SB1, 6 mm Diam. x 36"L



POLISHED BRASS

End Post: 01HC9014PB1
.906" DIAM. x 1.575" H
Center Post: 01HC9015PB1
.906" DIAM. x 1.575" H
Corner Adapter: 01HC9016PB1
1.102" DIAM. X 1.654"H
Rail: 01HC900436PB1, 6 mm Diam. x 36"L



CHROME

End Post: 01HC9014CR1
.906" DIAM. x 1.575" H
Center Post: 01HC9015CR1
.906" DIAM. x 1.575" H
Corner Adapter: 01HC9016CR1
1.102" DIAM. X 1.654"H
Rail: 01HC900436CR1, 6 mm Diam. x 36"L



DOUBLE CONTEMPORARY



Pictured in Flat Black



STAINLESS STEEL

End Post: 01HC9024SS1
1.063" DIAM. x 1.693" H
Center Post: 01HC9025SS1
.906" DIAM. x 1.575" H
Corner Adapter: 01HC9026SS1
1.102" DIAM. X 1.654"H
Rail: 01HC900436SS1, 6 mm Diam. x 36"L



FLAT BLACK

End Post: 01HC9024WR1
1.063" DIAM. x 1.693" H
Center Post: 01HC9025WR1
.906" DIAM. x 1.575" H
Corner Adapter: 01HC9026WR1
1.102" DIAM. X 1.654"H
Rail: 01HC900436WR1, 6 mm Diam. x 36"L



SATIN BRASS

End Post: 01HC9024SB1
1.063" DIAM. x 1.693" H
Center Post: 01HC9025SB1
.906" DIAM. x 1.575" H
Corner Adapter: 01HC9026SB1
1.102" DIAM. X 1.654"H
Rail: 01HC900436SB1, 6 mm Diam. x 36"L



POLISHED BRASS

End Post: 01HC9024PB1
1.063" DIAM. x 1.693" H
Center Post: 01HC9025PB1
.906" DIAM. x 1.575" H
Corner Adapter: 01HC9026PB1
1.102" DIAM. X 1.654"H
Rail: 01HC900436PB1, 6 mm Diam. x 36"L



CHROME

End Post: 01HC9024CR1
1.063" DIAM. x 1.693" H
Center Post: 01HC9025CR1
.906" DIAM. x 1.575" H
Corner Adapter: 01HC9026CR1
1.102" DIAM. X 1.654"H
Rail: 01HC900436CR1, 6 mm Diam. x 36"L



Check our price list or website for finish available for product.

GALLERY RAIL

CR
Chrome

PB:
Polished Brass

SB:
Satin Brass

SS:
Stainless Steel

WR:
Flat Black

DECORATIVE BRASS HARDWARE

Image: Knurled Brass Footrail



<https://bit.ly/Decorative-Brass-Hardware>

NEW! DESIGNER CANTILEVER BISTRO SHELVING

Available in Knurled, Reeded and Plain styles. Comes in Lacquered Polished Brass and Satin Brass finishes.



Image : Reeded Cantilever Shelving

DESIGNED FOR USE WITH 10" DEEP SHELVES ONLY
GLASS SHELVES NOT INCLUDED



KNURLED

3 SHELF
01KCANT1036-1
36" high, 13" deep

4 SHELF
01KCANT1048-1
48" high, 13" deep



REEDED

3 SHELF
01RCANT1036-1
36" high, 13" deep

4 SHELF
01RCANT1048-1
48" high, 13" deep



PLAIN

3 SHELF
01CANT1036-1
36" high, 13" deep

4 SHELF
01CANT1048-1
48" high, 13" deep

Custom finishes & sizes available.

BRASS HARDWARE

PB:
Polished Brass

SB:
Satin Brass

BRASS BISTRO SHELVING

Elevate your designs with the sophistication of Brass Bistro Shelving. Traditional, Contemporary and Cantilever Bistro Shelving Kits are stocked in Lacquered Polished Brass & Lacquered Satin Brass, with (5) custom finishes available*. Custom finishes include Antique Copper, Antique Brass, Flat Black, Satin Nickel, and Polished Nickel. Our Brass Bistro Shelving is easy to assemble with set screws and includes installation hardware and assembly instructions.

*Glass shelves not included. All Brass tubes are 1" Diameter. *Premium pricing applies for custom finishes.*

FLUSH



FOR 10" SHELVES:

3 SHELF
01FLUSH1036-1

42" high,
12.875" deep

4 SHELF
01FLUSH1048-1

56.5" high,
12.875" deep

FOR 12" SHELVES:

3 SHELF
01FLUSH1236-1

42" high,
14.875" deep

4 SHELF
01FLUSH1248-1

56.5" high,
14.875" deep

TRADITIONAL



FOR 10" SHELVES:

3 SHELF
01TRAD1036-1

42.25" high,
13.375" deep

4 SHELF
01TRAD1048-1

56.375" high,
13.375" deep

FOR 12" SHELVES:

3 SHELF
01TRAD1236-1

42.25" high,
15.375" deep

4 SHELF
01TRAD1248-1

56.375" high,
15.375" deep

We offer **Built-to-Order Bistro Shelving** in multiple configurations and finishes. Wall-to-floor, ceiling-to-countertop, and wall-to-countertop, you decide your connection points*, number of shelves and more by designing your own Built-to-Order Bistro Shelving. For Traditional and Contemporary Bistro Shelving styles, you can define the depth of your shelves (Cantilever arms have a fixed depth for use with 10" deep shelves).

*We do not offer ceiling-to-ceiling connection points.

**Unlacquered brass (due to its raw nature) will oxidize, causing a patina film to form, giving the brass a greenish look.

PLEASE NOTE: Premium pricing applies for custom finishes.

STOCK FINISHES

PB:
Polished Brass

SB:
Satin Brass

CUSTOM BISTRO FINISHES

**Unlacquered
Brass

Antique Brass

Flat Black

Antique
Copper

Polished
Nickel

Satin Nickel

NEW! BRASS POT RAIL KITS

Available in Knurled and Plain styles. Comes in Lacquered Polished and Satin Brass and Flat Black finishes. Each kit includes all necessary rail components, assembly/installation hardware and six matching s-hooks. Heavy duty brass hooks available separately (QHOOK-1).

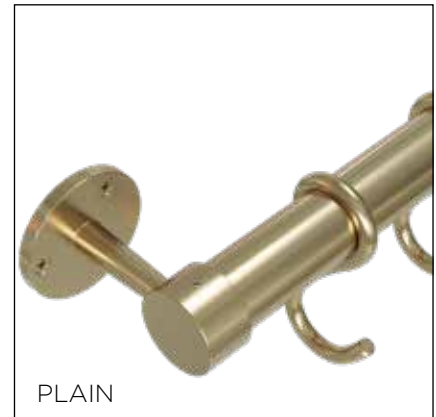

01POTRL-1-18 1" Diam. Pot Rail Kit - 18" L

01KPOTRL-1-18 Knurled Design, 1" Diam. Pot Rail Kit - 18" L

01RPOTRL-1-18 Reeded Design, 1" Diam. Pot Rail Kit - 18" L



01POTRL-1-24 1" Diam. Pot Rail Kit - 24" L

01KPOTRL-1-24 Knurled Design, 1" Diam. Pot Rail Kit - 24" L

01RPOTRL-1-24 Reeded Design, 1" Diam. Pot Rail Kit - 24" L



01POTRL-1-30 1" Diam. Pot Rail Kit - 30" L

01KPOTRL-1-30 Knurled Design, 1" Diam. Pot Rail Kit - 30" L

01RPOTRL-1-30 Reeded Design, 1" Diam. Pot Rail Kit - 30" L

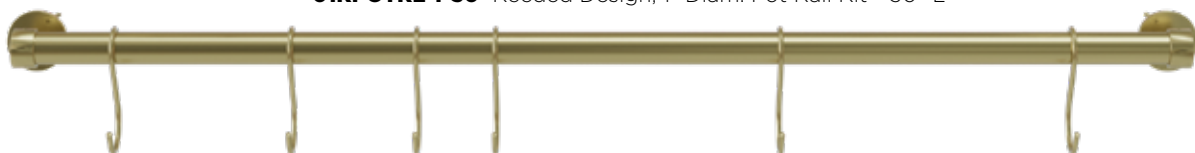

01POTRL-1-36 1" Diam. Pot Rail Kit - 36" L

01KPOTRL-1-36 Knurled Design, 1" Diam. Pot Rail Kit - 36" L

01RPOTRL-1-36 Reeded Design, 1" Diam. Pot Rail Kit - 36" L

BRASS HOOK

Pairs great with our Pot Rail Kit.



QHOOK-1

Fits 1" diam. rod
MUST BE PURCHASED SEPARATELY

3 styles, custom finishes & sizes available.

Check our price list or website for finish available for product.

BRASS HARDWARE

PB:
Polished Brass

SB:
Satin Brass

WR:
Flat Black

NEW! BRASS CONTEMPORARY FOOT RAIL KITS

Add luxury and detail to home bars and kitchens with **Brass Foot Rail Kits** — crafted from **solid cast brass** with a **Knurled** or **Reeded texture**. Designed for residential scale with **1.5" diameter components**, kits are available in 4-ft, 5-ft, and 8-ft lengths. **Modular components** available, allowing for custom configurations and one-of-a-kind installations.

REEDED FOOT RAIL KITS



4' REEDED KIT INCLUDES:

- (1) 48" Pole
- (2) 90° Posts
- (2) End Caps
- (1) Straight Post

01RFOTRL1SB1-48

5' REEDED KIT INCLUDES:

- (1) 60" Pole
- (2) 90° Posts
- (2) End Caps
- (2) Straight Posts

01RFOTRL1SB1-60

8' REEDED KIT INCLUDES:

- (2) 48" Poles
- (3) 90° Posts
- (2) End Caps
- (2) Straight Posts

01RFOTRL1SB1-96

CORNER CONNECTOR ADD-ON



01474150-1

1.389" x 3.425" x 3.425"

KNURLED FOOT RAIL KITS



4' KNURLED KIT INCLUDES:

- (1) 48" Pole
- (2) 90° Posts
- (2) End Caps
- (1) Straight Post

01KFOTRL1SB1-48

5' KNURLED KIT INCLUDES:

- (1) 60" Pole
- (2) 90° Posts
- (2) End Caps
- (2) Straight Posts

01KFOTRL1SB1-60

8' KNURLED KIT INCLUDES:

- (2) 48" Poles
- (3) 90° Posts
- (2) End Caps
- (2) Straight Posts

01KFOTRL1SB1-96

CORNER CONNECTOR ADD-ON



01474150-1

1.389" x 3.425" x 3.425"

WARRANTY INFORMATION

RETURNED GOODS POLICY

Request Timeline & Address

Returns must be requested **within 30 days** of receipt (delivery or will-call pickup). Please inspect products immediately upon receipt.

Returns must be sent to:

7040 N. Lawndale Ave., Lincolnwood, IL 60712 unless otherwise instructed by Brown Wood.

RETURN CATEGORIES

1. Customer-Responsible Returns

- 15% restocking fee (product cost only)
- Customer pays return shipping
- Initial shipping charges are non-refundable
- Restocking fee may be waived with replacement order at time of return
- Common reasons: incorrect item ordered, over-ordering, no longer needed, buyer's remorse.

2. Manufacturer-Responsible Returns

- No restocking fee
- Manufacturer pays return shipping
- Original shipping & handling costs refunded
- Requires photographic verification
- Common reasons: incorrect or defective items, inaccurate description, shipping errors.

Return Conditions (All Returns)

- Returns require prior approval and an RMA number. Contact us: orders@brownwoodinc.com
- Items must be eligible (see below)
- Returned within 14 days of RMA approval
- Product must arrive in same condition as reported at time of RMA approval
- Package must include RMA or invoice reference
- Refunds are issued within 5-7 business days of receipt.

RETURN ELIGIBILITY

Not returnable:

- Cut-to-size items (grille, mesh, rattan, resin, leather)
- 96" mouldings/tambour cut for shipping
- Custom-serviced parts (split, routed, notched, etc.)
- Altered, painted, sanded, installed, or otherwise modified items
- Products returned after 30 days
- Large-Order Agreement items
- Custom size/species/design items

Eligible (exceptions within 30 days):

- Manufacturer cut items with incorrect dimensions
- Incorrect spec, quality, or item shipped
- Custom items not matching quote specs

Note: Always inspect products before any modifications. Any alteration cancels return eligibility.

ITEMS DAMAGED/LOST IN SHIPPING

Responsibility for the shipment passes to the carrier once the item leaves our facility. However, we package products to the highest standards to avoid transit damage.

What You Should Do Upon Delivery:

- Note visible damage on delivery receipts or freight bills
- Photograph all package and product damage if visible
- Open and inspect all packages within 14 days of delivery
- Check for missing parts or damage regardless of packaging condition
- Move items to safe, temperature-controlled storage promptly

For questions or assistance:

888-528-1440

orders@brownwoodinc.com

WARRANTY INFORMATION

Brown Wood Products Company and its brand, Designs of Distinction®, provide a 1-year product warranty from the date of delivery to the original purchaser.

Coverage

Products will be free from defects in materials and workmanship under normal household use.

Not Covered

- Neglect, misuse, accidents, alterations, extreme conditions
- Exposure to water, humidity, or outdoor use
- Post-sale finishing
- Faulty installation or utilization
- Natural aging, wear, fading, color variations
- Improper cleaning or storage

COMPONENT-SPECIFIC NOTES

Unfinished Wood

- Seal ends promptly
- Cracking from improper storage not covered
- Clean only with dry cloth or compressed air

Pre-Finished Wood

- Finish fading is natural and not covered
- Avoid ammonia, alcohol, or abrasive cleaners

Brass Components

- **Unlacquered:** Patina and oxidation expected (not covered)
- **Lacquered:** Clean gently to preserve finish

Electroplated Products

Color variation may occur between runs. Seamless match not guaranteed.

Anodized Aluminum

- Resistant to rust, but must be dried after cleaning
- Extended exposure to moisture voids warranty

UHB Tape & Designer DripEdge™

- Apply to clean surfaces with pressure
- Do not use in unsupported vertical applications

Gallery Rail

For display use only. Not structurally rated.

Samples & Sample Kits

For viewing only. Size/appearance may differ from final product.

Sustainable Materials

Rattan, resin, leather, mesh are prone to aging. Natural wear not covered.

Assembly/Installation

- Must be installed by responsible and experienced individuals
- Improper use or alteration voids warranty

Need Help?

If you have questions about returns, shipping, or warranty:

888-528-1440

orders@brownwoodinc.com

SAFETY INFORMATION

SAFETY & PROPOSITION 65 INFORMATION

Safety & Handling Notice

At **Designs of Distinction™ by Brown Wood, Inc.®**, we are committed to delivering high-quality components and materials. Our products are designed to meet reasonable safety standards when handled with care and proper preparation.

Whether you're assembling, installing, or finishing an item, always follow included instructions and use basic safety practices. Personal protective equipment (PPE)—such as gloves, goggles, dust masks, and hearing protection—should be used when cutting, drilling, sanding, or applying finishes.

Improper handling or failure to follow instructions may result in injury or product damage.

Wood Products

Most of our hardwood products (e.g., columns, corbels, mouldings, legs, tambour) are sold unfinished. These may include splinters or loose fibers. Activities like sanding, cutting, or finishing generate dust and debris—use PPE and proper ventilation.

Finished wood with clear-coat or other finishes should be treated the same, with added care during sanding or thinning, as finishes may release chemical particles. Avoid inhalation or ingestion.

- Wood Dust - <https://www.osha.gov/wood-dust>
- Sanding Safety - https://ag.purdue.edu/department/fnr/lab-sites/woodresearch/_docs/safesander.pdf
- Splinter Removal - <https://www.popularwoodworking.com/arts-mysteries/splinters-every-woodworkers-nemesis/>
- Eye Safety - <https://www.mayoclinic.org/first-aid/first-aid/basics/art-20056645>

California Proposition 65 Warning: Drilling, sawing, sanding, or machining wood products can expose you to wood dust, a substance known to the State of California to cause cancer. Use PPE and avoid inhaling dust. Learn more at www.P65Warnings.ca.gov/wood.

Metal Products

Our metal items—such as shelving, trim, feet, rails, and grilles—are made from brass, aluminum, or steel:

- **Brass** may contain fine dust or shavings and can be sharp when cut.
- **Aluminum** (sometimes anodized or coated) may release debris when worked.
- **Steel** grilles and mesh may buckle or create sharp fragments during handling or cutting.

Always use PPE and make sure you're familiar with your tools and procedures.

- Metal Cutting Safety - <https://www.metals4u.co.uk/blog/how-to-cut-metal-a-focus-on-safety>
- Powder Coating Safety - <https://www.tcipowder.com/resources/safety-compliance>
- Treating Metal Wounds - <https://www.mayoclinic.org/first-aid/first-aid/cuts/basics/art-20056711>

Other Materials

- **Rattan** is natural but may have surface residue—clean before use.
- **Resin** can release airborne particles when cut—use a dust mask and goggles.
- **Leather** may shed when trimmed—handle with care.
- **Glue & Tape** may contain chemicals—follow included directions and dispose of properly.

Use all products in a ventilated area and wear PPE suited to the task.

Safe Handling of Adhesives -

<https://www.adhesivesmag.com/articles/86751-safety-first-safe-handling-of-adhesives-and-sealants>

Recommended PPE (via Zoro Tools)

These are general-use items and do not guarantee safety:

- Work Gloves
- Safety Goggles
- Dust Masks / Respirators
- Aprons, Ear Protection, First Aid Kits & More

Final Reminder

Review all instructions before beginning any project, and only use tools and materials you are comfortable and familiar with. Your safety starts with preparation—use all products responsibly.

PART NUMBER INDEX

MATERIALS: TAMBOUR/ REEDED PANELS

011248100-1	2
011296100-1	2
012448100-1	2
011248101-1	2
011296101-1	2
011248102-1	2
011296102-1	2
012448102-1	2
011248103-1	2
011296103-1	2
011248104-1	2
011296104-1	2
011248105-1	2
011296105-1	2
011248106-1	2
011296106-1	2
011248107-1	2
011296107-1	2
012448107-1	2
011248110-1	2
011296110-1	2
012448110-1	2
011248302-1	3
011296302-1	3
012448302-1	3
011248304-1	3
011296304-1	3
012448304-1	3
011248402-1	3
011296402-1	3
012448402-1	3
011248403-1	3
011296403-1	3
012448403-1	3
011248201-1	4
011296201-1	4
011248202-1	4
011296202-1	4
011248203-1	4
011296203-1	4
012448203-1	4
011248204-1	4

011296204-1	4
011248206-1	4
011296206-1	4
011248207-1	4
011296207-1	4
012446100-1	5
012446102-1	5
012446107-1	5
012446110-1	5
012446127-1	5
012446302-1	5
012446304-1	5
012446402-1	5
012446403-1	5
014848127-1	6
019648127-1	6

MATERIALS: METAL ACCENT TRIM

010451-1-1181	8
01110451-1-12	8
01110451-1-14	8
010451-1-1481	8
01110451-1-15	8
01110451-1-17	8
010451-1-1781	8
010451-1-1875	8
010451-1-2050	8
010451-1-2081	8
010451-1-2175	8
010451-1-2350	8
010451-1-2384	8
01TP1875-54	8
01TP1875-8	8
01TP50-108	8
01TP50-8	8
01PEN-1	8
01110788-1	9
01110810-1	9
01200250-1	9
01110030-1	9
01110451-1	9
01-RAP7572-1	10
01110171-1	10

01HC1005-1	11
01HC1010-1	11
01HC1008-1	11
01990810-1	11
01HC1007-1	11

MATERIALS: CUT-TO-SIZE

012248MESH-1	13
014448MESH-1	13
013624M22-1	14
013648M22-1	14
011848M22-1	14
011848332P-1	14
012472332P-1	14
013624332P-1	14
013648332P-1	14
011848CG10-1	14
012472CG10-1	14
013624CG10-1	14
013648CG10-1	14
011848286S-1	14
012472286S-1	14
013624286S-1	14
013648286S-1	14
011848DK08-1	14
012472DK08-1	14
013624DK08-1	14
013648DK08-1	14
01184811614P-1	14
01247211614P-1	14
01362411614P-1	14
01364811614P-1	14
0118481214F-1	14
0124721214F-1	14
0136241214F-1	14
0136481214F-1	14
0118481220T-1	14
0136241220T-1	14
0136481220T-1	14
011848R332P-1	14
013624R332P-1	14
013648R332P-1	14
011848R614P-1	14
013624R614P-1	14

013648R614P-1	14
011848315C-1	14
012472315C-1	14
013624315C-1	14
013648315C-1	14
013624226-1	14
013648226-1	14
011848226-1	14
01SQ2472214F-1	15
01SQ3624214F-1	15
01SQ3648214F-1	15
01SQ1848214F-1	15
01SQ2472286S-1	15
01SQ3624286S-1	15
01SQ3648286S-1	15
01SQ1848286S-1	15
01SQ1848DK08-1	15
01SQ2472DK08-1	15
01SQ3624DK08-1	15
01SQ3648DK08-1	15
01SQ2472332P-1	15
01SQ3624332P-1	15
01SQ3648332P-1	15
01SQ1848332P-1	15
011848RE25-1	15
012472RE25-1	15
013624RE25-1	15
013648RE25-1	15
01DGRETAINDER	15
01103	16
01110	16
01107	16
01112	16
0124481802	16
0148481802	16
0124481803	16
0148481803	16
0124481804	16
0148481804	16
013202	17
013201	17
011202NT1	17
011203NT1	17
011204NT1	17

011201NT1	17	01ANGLEPLATE	23	01042760-1	28	01635010-1	32
013216WR1	17	01STRAIGHTPLATE	23	01040260-1	28	01636010-1	32
015618WR1	17	01HDPLATE	23	01220260-1	28	01530310-1	33
012652-1	17	01724500-1	24	01250210-1	28	01540310-1	33
0124481652-1	17	01722010-1	24	01510228-1	28	01000310-1	33
0148481652-1	17	01622010-3	24	01515028-1	28	01160310-1	33
0124482216-1	17	01622025-3	24	01060260-1	29	01240310-1	33
0148482216-1	17	01622025-1	24	01060220-1	29		
		01622010-1	24	01510210-1	29		
		01623010-1	24	01060210-1	29	END PANELS	
POSTS & TABLE LEGS		01623025-1	24	01160210-1	29	01XPN3025LNG-1	35
01243029-1	20	01723010-1	24	01150220-1	29	01XPN3036LNG-1	35
01243024-6	20	01734510-1	24	01560210-1	29	01XPN1525LNG-1	35
01243018-6	20	01530210-1	25	01520210-1	29	01XPN1536LNG-1	35
01245129-1	20	01540210-1	25	01570217-1	30	01XPNL3025-1	35
01245129-8	20	01624010-1	25	01580217-1	30	01XPNL3036-1	35
01245124-1	20	01624025-1	25	01082710-1	30	01XPNL1525-1	35
01245124-8	20	01724010-1	25	01080210-1	30	01XPNL1536-1	35
01245118-1	20	01725010-1	25	01080270-1	30	01XPN3025LNG-4	36
01245118-8	20	01625010-1	25	01082740-1	30	01XPN3036LNG-4	36
01612010-1	21	01606010-1	25	01080240-1	30	01XPN1525LNG-4	36
01612010-3	21	01626010-1	25	01230210-1	30	01XPN1536LNG-4	36
01722910-1	21	01180210-1	26	01082730-1	30	01XPNL3025-4	36
01724529-1	21	01510202-1	26	01230240-1	30	01XPNL3036-4	36
01621025-1	21	01040240-1	26	01082730-1	30	01XPNL1525-4	36
01621025-3	21	01040210-1	26	01080230-1	30	01XPNL1536-4	36
01613010-1	21	01010285-1	26	01230230-1	30	01XBS34241	37
01613025-1	21	01010280-1	26	01140210-1	30	01XBS34361	37
01723001-1	22	01020280-1	26	01625046-1	31	01290180-1	37
01734529-1	22	01000210-1	27	01510204-1	31	01290280-1	37
01724001-1	22	01210210-1	27	01240210-1	31	01RADTBS2534-1	38
01614010-1	22	01030210-1	27	01090215-1	31	01RADTBS3634-1	38
01614025-1	22	01470210-1	27	01100211-1	31	01RADBS2534-1	38
01040127-1	22	01410210-1	27	01386050-1	31	01RADBS3634-1	38
01040160-1	22	01590222-1	27	01626050-1	31	01RECBASE-1	39
01220160-1	22	01590224-1	27	01110218-1	31	01RNDBASE345-1	39
01110110-1	22	01590227-1	27	01100218-1	31	01TRIBASE-1	39
01060160-1	22	01590223-1	27	01250310-1	32	01RECKIT100-1	39
01060110-1	23	01590225-1	27	01510328-1	32	01RECKIT302-1	39
01510110-1	23	01590228-1	27	01632010-1	32	01RECKIT304-1	39
01590122-1	23	01520223-1	28	01633010-1	32	01RECKIT402-1	39
01590124-1	23	01040270-1	28	01733010-1	32	01RECKIT403-1	39
01590127-1	23	01040275-1	28	01734010-1	32	01RNDKIT104-1	39
01000110-1	23	01110210-1	28	01634010-1	32	01RNDKIT106-1	39
01210110-1	23			01735010-1	32	01RNDKIT203-1	39

01RNDKIT206-1	39	01700310-1	45	01222006-6	48	01SLV5-1	50
01TRIKIT100-1	39	01705110-1	45	01222006-8	48	01SLPR106-1	50
01TRIKIT302-1	39	01704075-1	45	01223006-6	48	01SLPR105-1	50
01TRIKIT304-1	39	01700210-1	45	01223006-8	48	01SLPR104-1	50
01TRIKIT402-1	39	01706060-1	46	01223009-6	48		
01TRIKIT403-1	39	01700018-1	46	01223009-8	48	BRACKETS & CORBELS	
01EPS3025-1	40	01705155-1	46	01245106-6	48	01ARCHKNLD1-1	52
01EPS3036-1	40	01705150-1	46	01245106-8	48	01ARCHPLN1-1	52
01EPT1525-1	40	01700245-1	46	01245106-1	48	01600016-1	52
01EPT1536-1	40	01700245-6	46	01245109-6	48	01600006-1	52
01EPT3025-1	40	01700345-1	46	01245109-8	48	01651270-1	52
01EPT3036-1	40	01700345-6	46	01245109-1	48	01605006-1	53
01EPAR1525-1	40	01705310-1	47	01243006-1	48	01605007-1	53
		01760410-1	47	01243006-6	48	01605008-1	53
		01704210-1	47	01243006-8	48	01605009-1	53
FURNITURE & BUN FEET		01706010-1	47	01243009-6	48	01600300-1	53
01708310-1	42	01702510-1	47	01243009-8	48	01607012-1	53
01708010-1	42	01700015-1	47	01243009-1	48	01600001-1	54
01708110-1	42	01704110-1	47	01244006-6	48	01600002-1	54
01703110-1	42	01704010-1	47	01244006-8	48	01600003-1	54
01703010-1	42	01704040-1	47	01244006-1	48	01600009-1	54
01703210-1	42	01704910-1	47	01244009-6	48	01607009-1	54
01707410-1	43	01240006-6	48	01244009-8	48	01607008-1	54
01707440-1	43	01240006-8	48	01244009-1	48	01607006-1	54
01709010-1	43	01240006-1	48	01700400-1	49	01607007-1	54
01707710-1	43	01240009-6	48	01700402-1	49	01601400-1	55
01700457-1	44	01240009-8	48	01700012-1	49	01601300-1	55
01705710-1	44	01240009-1	48	01700905-1	49	01601100-1	55
01706065-1	44	01241006-6	48	01700408-1	49	01607004-1	55
01705080-1	44	01241006-8	48	01700406-1	49	01607001-1	55
01750460-1	44	01241006-1	48	01700412-1	49	01607005-1	55
01704060-1	44	01241009-6	48	01700410-1	49	01607117-1	56
01700146-1	44	01241009-8	48	01700401-1	49	01607217-1	56
01703510-1	44	01241009-1	48	01704017-1	49	01607317-1	56
01700627-1	44	01242006-1	48	01706018-1	49	01604510-1	56
01705860-1	44	01242006-6	48	01FRS1010-1	50	01604505-1	56
01705715-1	44	01242006-8	48	01FRS1254-1	50	01606002-1	56
01705175-1	45	01242009-1	48	01FRC1010-1	50	01606001-1	56
01705610-1	45	01242009-6	48	01FRC1040-1	50	01606003-1	56
01705112-1	45	01242009-8	48	01SLV245-1	50	01608009-1	57
01705510-1	45	01221006-6	48	01SLV345-1	50	01608007-1	57
01705810-1	45	01221006-8	48	01SLV2-1	50	01608010-1	57
01705225-1	45	01221009-6	48	01SLV3-1	50	01608008-1	57
01731010-1	45	01221009-8	48	01SLV4-1	50	01608001-1	57

01601205-1	57	01962020-2	64	OUTLETS & VENTS		DECORATIVE BRASS	
01601204-1	57	01391510-2	65	01450002-1	73	HARDWARE	
01601203-1	57	01311510-2	65	01451002-1	73	01KCANT1036-1	85
01607010-1	58	01312010-2	65	01450003-1	73	01KCANT1048-1	85
01607011-1	58	01331510-2	65	01451003-1	73	01RCANT1036-1	85
01607316-1	58	01332010-2	65	01453003-1	73	01RCANT1048-1	85
01607216-1	58	01321510-2	65	01454003-1	73	01CANT1036-1	85
01901005-1	58	01322010-2	65	01450001-1	73	01CANT1048-1	85
01901003-1	58			01451001-1	73	01FLUSH1036-1	86
01607315-1	58	DECORATIVE MOULDING		01453001-1	73	01FLUSH1048-1	86
01607215-1	58	& PILASTERS		01454001-1	73	01FLUSH1236-1	86
01901105-1	59	01SHIPLAP-1	67	01450012-1	74	01FLUSH12361	86
01901001-1	59	01827578-1	67	01451012-1	74	01FLUSH1248-1	86
01901002-1	59	01807375-1	67	01450013-1	74	01FLUSH12481	86
01901108-1	59	01807500-1	67	01451013-1	74	01TRAD1036-1	86
01901107-1	59	01807000-1	67	01452001-1	74	01TRAD1048-1	86
01901009-1	59	01806000-1	67	01452002-1	74	01TRAD1236-1	86
01600928-1	59	01MB867510-1	67	01992114-1	75	01TRAD1248-1	86
01600628-1	59	01MB867520-1	67	01992110-1	75	01POTRL1-1-18	87
01601427-1	60	01384210-2	67	01992124-1	75	01POTRL1-1-24	87
01600927-1	60	01384240-2	67	01992112-1	75	01POTRL1-1-30	87
01600627-1	60	01386050-1	67	01992214-1	75	01POTRL1-1-36	87
01600318-1	60			01992224-1	75	01KPOTRL1-1-18	87
01904991-1	60	SHELVING		01992210-1	75	01KPOTRL1-1-24	87
01904990-1	60	01MFL103030-1	69	01992212-1	75	01KPOTRL1-1-30	87
01901004-1	60	01MFL102424-1	69	01992010-1	76	01KPOTRL1-1-36	87
01904993-1	60	01MSH123030-1	69	01992012-1	76	01RPOTRL1-1-18	87
01605001-1	61	01MSH122424-1	69	01992014-1	76	01RPOTRL1-1-24	87
01605000-1	61	01MFL102410-1	69	01992024-1	76	01RPOTRL1-1-30	87
01605005-1	61	01MFL103610-1	69	01994014-1	76	01RPOTRL1-1-36	87
		01FL102410-1	70	01994012-1	76	01QHOOK-1	87
		01FL103610-1	70	01994010-1	76	01RFOTRL1-1-48	88
CREATE-A-COLUMN™/HALF		01CHSHLF0424-1	70			01RFOTRL1-1-60	88
ROUND MOULDINGS		01CHSHLF0436-1	70	GALLERY RAIL		01RFOTRL1-1-96	88
& CORNER MOULDINGS		01CHSHLF0448-1	70	01HC9001-1	82	01KFOTRL1-1-48	88
01RADCRN297-1	63	01CHSHLF0460-1	70	01HC9002-1	82	01KFOTRL1-1-60	88
01RADCRN397-1	63	01CHSHLF0624-1	70	01HC9003-1	82	01KFOTRL1-1-96	88
01RADCRN697-1	63	01CHSHLF0636-1	70	01HC900436-1	82	01474150-1	88
01962010-2	64	01CHSHLF0648-1	70	01HC9014-1	83		
01961510-2	64	01981515WR1	71	01HC9015-1	83		
01961530-2	64	01982222WR1	71	01HC9016-1	83		
01961540-2	64	01980109WR1	71	01HC9024-1	83		
01962040-2	64	01981022WR1	71	01HC9025-1	83		
01961520-2	64	01980116WR1	71	01HC9026-1	83		



Designs of distinction[®]
Kitchen, Bath & Home
by BWI

dod.brownwoodinc.com • @designsofdistinction_kbh